

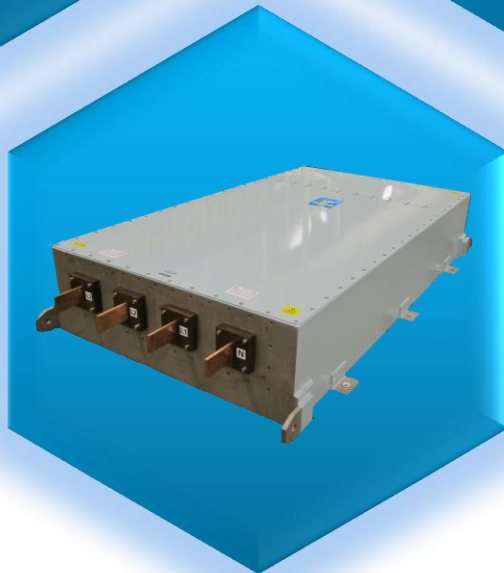

MPE
Quality, Reliability, Performance

HIGH PERFORMANCE POWER LINE FILTERS



FM00699

MPE Limited
Hammond Road
Knowsley Industrial Park
Liverpool L33 7UL



This catalogue details high performance low pass power line filters in current ratings from 5A to 2400A.

Specifically designed by MPE to offer the highest possible performance in a given package size, coupled with very high reliability, these filters are suitable for a wide variety of applications.

These filters incorporate MPE proprietary metallised plastic film feedthrough capacitors with self-healing properties. These capacitors employ the best technology for this type of EMI filter for providing very high reliability, low losses and performance up to very high frequencies of 40GHz and beyond.

Filters in this catalogue have been tested after more than 20 years continuous service and shown not to have exhibited any significant degradation, which endorses the claims of high reliability. Customer returns of filters in this catalogue due to electrical problems have been less than 0.1% over a 20 year period.

In addition to our well known single and three phase designs, additional filter ranges are included for more specialised applications. These ranges include d.c. power line filters and single line filter designs in compact tubular and rectangular case styles.

All filters in this catalogue up to and including 400A are RoHS compliant. Higher current filters than this will always be used in large scale fixed installations so are specifically excluded from the scope of the directive

The technical notes on the following pages should be consulted for detailed information on different types of filters and their applications. A brief summary of selection criteria is given below, and a more detailed application guide is given on page 3.

- For most single and three phase mains applications, the ideal filter choice should be a multiple line filter incorporating current compensating inductors.
- Where enhanced safety and leakage current are major considerations on single and three phase mains applications, the best choice is a low leakage filter incorporating current compensating inductors.
- Where single a.c. lines such as control lines need filtering then a single line a.c. filter design should be used.
- For two line d.c. filtering with return current flowing through the filter, then a d.c. filter incorporating current compensating inductors is the best choice.
- For single line d.c. filtering of supplies using an earth return, a single line d.c. filter should be used.
- For HEMP filters meeting the requirements of Mil-Std-188-125-1 and -2 and Def-Stan 59-188 Parts 1 & 2, please see our separate HEMP Filters catalogues.
- Where power filters with slightly lower performance up to 1GHz is sufficient then please see our CleanPower filters catalogue.
- All filters rated at 250VAC 50/60Hz are also suitable for 277VAC 50/60Hz and filters rated at 250/440VAC 50/60Hz are also suitable for 277/480VAC 50/60Hz. Alternative varistor ratings may be required on transient suppressed versions

All MPE power filters are tested using the test methods defined within the following standards and meet or exceed the relevant performance and/or safety criteria defined within these standards: Mil-F-15733, Mil-Std-220C, CISPR17:2011/BS EN 55017:2011, UL1283, EN60950/IEC60950/UL60950



Applications \ Products	DC Filters			AC Filters								
	Single Line (Tubular Case)	Single Line (Rectangular Cases)	Two Line	Single Line (Tubular Case)	Single Line (Rectangular Cases)	Standard Range SP&N and TP&N	Extended Performance (SP&N and TP&N)	Low Leakage Standard Performance (SP&N and TP&N)	Low Leakage Extended Performance (SP&N and TP&N)	Two Phase	400Hz (SP&N and TP&N)	Low Leakage High Current (SP&N and TP&N)
Page Number of Filter Range	11	13	15	17	19	21	23	25	27	29	31	33
Single line d.c. supplies	•	•		◇	◇							
Two line d.c. supplies (with load current returning through filter)	◇	◇	•			◇	◇					
Single line a.c. supplies				•	•							
Single phase plus neutral supplies				◇	◇	•	•					
Single phase plus neutral supplies with low-leakage requirement								•	•			
Three phase supplies with or without neutral				◇	◇	•	•					•
Three phase plus neutral supplies with low leakage requirement								•	•			•
Balanced single phase supplies (no neutral) & two phase supplies				◇	◇					•		
400Hz supplies											•	
High current supplies 800A upto 2400A						•						•

• = Best Option

◇ = Alternative



Page No.	Contents/ Filter Range	Voltage Rating	Current Rating	100dB Insertion loss from
5	MPE Limited	-	-	-
6	Technical Information	-	-	-
11	Single Line DC (Tubular Cases)	250VDC	6 - 200A	80kHz 200kHz 500kHz
13	Single Line DC (Rectangular Cases)	250VDC	6 - 200A	10kHz
15	Two Line DC	250VDC	6 - 200A	10kHz
17	Single Line AC (Tubular Cases)	250VAC	6 - 200A	350kHz 900kHz 2MHz
19	Single Line AC (Rectangular Cases)	250VAC	6 - 200A	14kHz
21	Standard Range (SP&N and TP&N)	250/440VAC	6 - 1200A	10kHz 50kHz 100kHz
23	Extended Performance (SP&N and TP&N)	250/440VAC	6 - 400A	10kHz
25	Low Leakage (SP&N and TP&N)	250/440VAC	6 - 400A	50kHz 100kHz
27	Low Leakage Extended Performance (SP&N and TP&N)	250/440VAC	6 - 400A	10kHz
29	Two Phase Range	250/440VAC	6 - 400A	50kHz 100kHz
31	400Hz Range (SP&N and TP&N)	115/200VAC 400Hz	6 - 200A	100kHz
33	Very High Current (TP&N)	250/440VAC	800 - 2400A	10kHz 100kHz
37	Fixing Kits	-	-	-
38	Outline Dimensions	-	-	-
40	Outline Dimensions	-	-	-
42	Installation Details	-	-	-
43	Custom Designs	-	-	-

Note 250VAC. filters are also suitable for 277VAC.
250/440VAC. filters are also suitable for 277/480VAC
Transient suppressed versions will need alternative varistor ratings for these voltages – please ask.



Introduction

MPE's reputation as one of Europe's leading filter specialists is based on over 90 years experience in the design, development and production of high performance radio frequency interference filters and custom capacitors. Our commitment to a policy of continuous product development and innovation has resulted in one of the most comprehensive ranges of filter products available from a single manufacturer.

The latest filter technology has been developed and adapted to new requirements by maintaining continuous close liaison with Government Agencies and Defence Contractors, both in the UK and abroad. Our unrivalled capability and experience enables us to design and build filters and systems to suit almost any application.

In addition to the power line filters covered by this catalogue, standard products manufactured by MPE range from sub-miniature ceramic filters for avionics and missile systems, through precision filters for telephone and data lines to high current HEMP filters.

Non-standard requirements can be fulfilled by a custom designed filter or capacitor from a very diverse range and capability also offered by MPE. To complement our filter products, we can also supply fixing kits, RFI trunking and shielded termination enclosures. Installation advice and site testing services are available.

Approvals

Apart from many individual vendor approvals, MPE holds the following factory accreditation.

BS EN ISO9001:2008

Numerous product approvals and registrations include:

- British Telecom Approvals for Telephone Filters
- Defence Standard Approvals
- NATO Stock Number Listings
- FV (Fighting Vehicle) registered designs
- TEMPEST recommended products
- HEMP type-tested filters to Mil-Std-188-125

Manufacturing Capability

Strict control over critical processes is maintained by carrying out all key manufacturing operations ourselves at our Liverpool factory. This also ensures maximum flexibility for producing custom designs. Special environmentally controlled production areas are dedicated to the manufacture of capacitors and inductors.

We also have dedicated areas for enclosure fabrication, sub-assembly manufacture, resin encapsulation, paint finishing, and high voltage testing.

Design and Development

Members of our design team are always available to offer technical support and can visit your premises, if required, to discuss project requirements at an early stage.

Extensive use is made of computer aided capacitor and filter design techniques and circuit modelling programs. Theoretical performance is always validated by prototype testing.

Diagnostic EMC analysis of your equipment can be carried out in our screened room installation to provide cost effective filter solutions based on our extensive design experience.

The development test laboratory is well equipped with specialist facilities and is capable of carrying out a variety of special tests including high energy EMP pulse injection testing to 5kA, and high current load testing to 3000A.

Quality

All products are 100% tested under ISO9001:2008 controls prior to leaving our factory.

We also have specialised test equipment including our fully equipped RFI test facilities and screened room. We are able to undertake complete type test approval programmes to both military and commercial specifications.

Reliability of products and technology employed is field proven over more than 25 years. Filters have been tested after 20 years in service and found to comply with their original specification.

Electrical field returns are negligible and are believed to be the lowest in the industry.



Terminology

RFI: Radio Frequency Interference.

Traditionally considered to cover the radio spectrum 150kHz - 300MHz.

EMI: Electro Magnetic Interference.

A more modern term covering 10kHz - 10GHz.

EMC: Electro Magnetic Compatibility.

The ability of equipments and systems to function as designed in an electromagnetic environment.

EMP/HEMP: (High Altitude) Electromagnetic Pulse. Usually generated by a nuclear explosion, EMP is a high energy pulse capable of damaging most types of unprotected electronic equipment.

TEMPEST: This is the need to prevent equipment from generating conducted or radiated EMI containing intelligible information.

Application Information

RFI/EMI/EMC

All filters in this catalogue have wide application in the EMC field where high performance is required. They are ideal for filtering mains services to screened enclosures against both incoming and outgoing noise and transients. They are equally suitable for the protection of permanently wired equipment such as computer installations.

With the increasing importance of filtering down to low frequencies, it should be noted that many of the filter ranges within this catalogue will offer 100dB performance even down to 10kHz.

EMP Protection Systems

EMP protection systems normally comprise a primary protection component, an inductive delay element, and a filter.

Most filters in this catalogue, by virtue of their performance, are ideally suited for use in such systems. Most of the ranges will meet insertion loss requirements required for EMP applications. Transient suppressed versions of filters should be selected for use in EMP protection systems. However, for full HEMP protection filters in a single package meeting the requirements of Mil-Std-188-125-1 and -2 and also DEF-Stan 59-188 parts 1 and 2, please consult our separate HEMP filter catalogues covering power line HEMP filters from 6A to 1200A. These filters have been independently tested to the Mil-Std-188-125 specification and shown to be fully compliant. HEMP filters for control and telephone lines are also available.

Tempest Applications

Where the integrity of secure information is concerned, maximum filtering performance across the widest range of frequencies is vital. This catalogue includes several ranges of filters which offer a very wide stopband performance of 100dB from 10kHz to well above 10GHz. Because of the design of the proprietary MPE feedthrough capacitors, most filter ranges will continue to offer full performance to >40GHz.

MPE have produced many special designs for TEMPEST applications, and are familiar with the latest TEMPEST requirements.

Electrical Design Features

Multiple Line Filters with Current Compensating Inductors

All multiple line filters in this catalogue use a modern filter design employing toroidal current compensating inductors or "coupled chokes". Multiple windings are used on the same inductor core to achieve flux cancellation and thus full insertion loss performance up to full rated current as the inductor does not saturate.

Empirical testing has proven that this advanced filter design gives identical insertion loss performance under no-load, half-load, and full-load current conditions over the full frequency range.

The use of current compensating inductors permits the use of high permeability cores to give large inductance values. This results in a much higher performance filter with lower leakage current and lower heat dissipation than for the older type of single line filter design still used by many manufacturers of power line filters. (Single line filters have been widely used in the past for many applications but they have a number of significant disadvantages including the loss in performance as load current increases.)

To ensure maximum benefit is obtained from MPE's highly efficient coupled choke filter designs, the load current must always return through the filter to achieve current cancellation i.e. these filters should not be used on single lines, and on the load side of the filter the neutral must not be earthed or joined to neutrals from other sources.

As current returns through the filter in most power line applications, this type of filter design should always be the first choice for power lines as it offers the best size and performance combination.

These filter designs are equally suitable for three phase supplies with no neutral. The filter neutral line should be left unconnected, and must not be grounded.

Single Line Filters

There are some special applications where single line filters may still be required such as where there may be a common return or an earth return path. To satisfy such requirements, this catalogue also includes single line filter designs up to 200A.

On any single line filter, the inductor core will progressively saturate as the load current is increased, and the filter insertion loss at low frequencies will consequently reduce.

On our single line filters, the insertion loss figures quoted are the full load performance figures. As the load current is reduced, a higher performance will thus be provided by the filter. Single line filters are particularly suitable for control line applications. However, in control line applications, consideration should always be given to compatibility between the control circuits and the filter circuitry in terms of capacitance to earth, discharge resistors, d.c. resistance etc.

Our separate catalogue on control line filters offers complementary ranges of high performance control line filters covering lower current ratings down to 1A. If you have any doubt about your application, we will be pleased to advise the best filter solution.

Capacitors

The latest metallised plastic film dielectric capacitors are used in all of MPE's power line filters for maximum reliability and size efficiency. In a.c. filter designs, series metallised capacitors are used with very high overvoltage capability to give a high safety factor and excellent reliability.

High quality feedthrough capacitors are used in all filters to provide good transient handling capability and optimum high frequency performance.

Discharge Resistors

For enhanced safety, all filters in this catalogue are fitted with internal discharge resistor networks. These are intended to discharge the capacitors to a safe voltage within one minute of removing power from the filter. As the resistance of the discharge network will always be less than 1 Megohm, the use of a 'Megger' type instrument to check installed filters could erroneously indicate a fault so should only be used with caution (and should not be used at all on transient suppressed filters).

Transient Suppression

By virtue of their low inductance feedthrough construction, MPE's filter input capacitors are extremely effective in absorbing voltage transients even for rapid pulses with nanosecond rise times. Where an extra stage of transient suppression is required, or when the energy or the voltage of incoming transients is likely to exceed the capability of the filter capacitors, filters can be supplied with varistor transient suppressors fitted to the filter input terminals to provide additional protection. These filters are specially designed to permit easy renewal of transient suppressors, if necessary.

Overload Withstand Capability

Unless otherwise stated, filters in this catalogue are designed to meet the following overload conditions:

Current Overload:

10 times maximum rated current for 1 second.

1.5 times maximum rated current for 10 minutes.

It is not recommended that any filter is operated above its continuous rated current for any extended period because of the substantial heating effect of overload current.

Voltage Overload:

1.1 times maximum rated voltage continuously.

1.5 times maximum rated voltage for 1 minute. (excluding transient suppressed types)

D.C. filters are proof voltage tested at twice rated voltage.

All a.c. filters in this catalogue are proof voltage tested between each live line and earth at 2250V d.c. and at least 1150VDC between live and neutral lines. Proof voltage is carried out at least 3 times before filters leave the factory.

Factory tests are carried out prior to fitting of transient suppressors and should not be repeated.

Overvoltage testing (including "Megger") should not be carried out on transient suppressed filters as the varistors could be damaged.

A.C. filters are designed for use on mains supplies with no more than 5% total harmonic distortion.

Volt Drop

Volt drop figures, where quoted, relate to the resistive volt drop per line. It is measured using a d.c. current equivalent to the full load r.m.s. current. This is generally of more interest to the user than a.c. volt drop as it relates directly to power dissipation.

Low Leakage Filters

To provide good low frequency performance, all conventional a.c. power line filters have large values of capacitance between live and earth lines. This gives rise to a mains frequency leakage current which can be up to several amps in very high performance filters.

MPE's proprietary low leakage filter designs have no direct capacitance from live to earth but rather have capacitance from live to neutral and from neutral to earth. This means that the continuous earth leakage current depends only on the neutral to earth voltage, and may be as little as 15mA per N-E volt at 50Hz. In practice, the value achieved may be somewhat higher depending on the harmonic content of the neutral waveform.

Low leakage filters are intrinsically safer than conventional filters because of their lower earth leakage current, and because the leakage current is derived from a low source potential.

All of our ranges of low leakage filters incorporate our modern current compensated choke design, as previously described.

To ensure that low leakage filters operate correctly, they must be used on a supply with a neutral, and terminal polarity must be observed. The neutral should not be earthed on the load side of the filter.

N.B. Conventional three phase filters will also provide a low earth leakage current due to cancelling of the earth leakage currents from three phases, but will not share the enhanced safety benefits of low leakage designs.

Two Phase Filters

This range of filters has been specifically developed to provide optimum performance under the special conditions where two phases are taken from a three phase supply, instead of live and neutral. These filters are also ideal where a single phase supply is "floating" with neither line tied to neutral, such as in certain shipborne applications, or where isolating transformers are used.

400Hz Filters

In all 400Hz filters, leakage current is higher than for 50Hz filters because of the increased operating frequency. Where generators are used, it should be remembered that the generator must supply not only the load current but also the filter reactive (leakage) current. Consideration should be given to any harmonics on the 400Hz supply which may cause additional heating within filters.

In addition to using low loss capacitors to minimise heat dissipation, our ranges of 400Hz filters incorporate current compensating inductors as previously described. This gives the added benefit of reduced capacitance values and consequently lower leakage currents to achieve a given performance, compared to single line filter designs.

Very High Current Filters

Our unique ranges of very high current filters up to 2400A also offer the benefits of using current compensating inductors. For filters of such a high current rating, they offer exceptional performance, and have very low heat dissipation giving low running costs and higher reliability.

The busbar connections may either be drilled or clamped, to ensure low resistance power connections are made. Because of the very high current ratings, it is important that all conductors pass through a common cable entry point to avoid eddy current heating effects.

In view of the specialist nature of these filters, customised terminal chambers can be supplied to interface to individual installations.

Insertion Loss Performance

All filters detailed in this catalogue are high performance types designed to offer in excess of 100dB insertion loss to well beyond 10GHz.

Although testing above 10GHz is less meaningful, testing in a 50 ohm system yields insertion loss figures of typically 100dB up to 40GHz and even 80-100dB at 50GHz for most filters in this catalogue. Insertion loss performance quoted in this catalogue has been measured in the asymmetric mode in a 50 ohm system, generally in accordance with BS EN 55017:2011 (CISPR17). Most filters will also give very substantial symmetric mode performance.

For single and three phase filters incorporating current compensating inductors, measurement is carried out in the asymmetric mode with all input and output lines connected in parallel in accordance with BS EN 55017:2011

Typical measured performance figures are quoted in this catalogue. For higher performance filters, the measured values quoted may be restricted by test equipment limitations. Special measurement techniques have shown the true performance to be between 120dB and 140dB in many cases.

All new filter designs are empirically checked for insertion loss up to 4GHz. Sample tests at 10GHz and 18GHz by independent test authorities have verified that full 100dB performance has been maintained even at these very high frequencies. Integrity of production filters is guaranteed by 100% testing for capacitance, power factor, inductance, voltage proof, insulation resistance, and volt drop.

Insertion Loss in Different Impedance Systems

It must be recognised that insertion loss measurements made in a 50 ohm system (while giving good guidance and comparative performance figures) may differ from those achieved in practical situations.

This is because although mains supplies are assumed to be 50 ohm impedance as far as RFI is concerned, in practice the terminating impedances can be somewhat different.

In fact, the source impedance is likely to be much less than 50 ohms at lower frequencies. BS EN 55017 (CISPR 17) recognises this fact and suggests an alternative insertion loss test with 0.1 ohm source and 100 ohm load impedances. Although closer to many real system impedances, even this test cannot represent every practical situation so test results should only be used for comparative guidance.

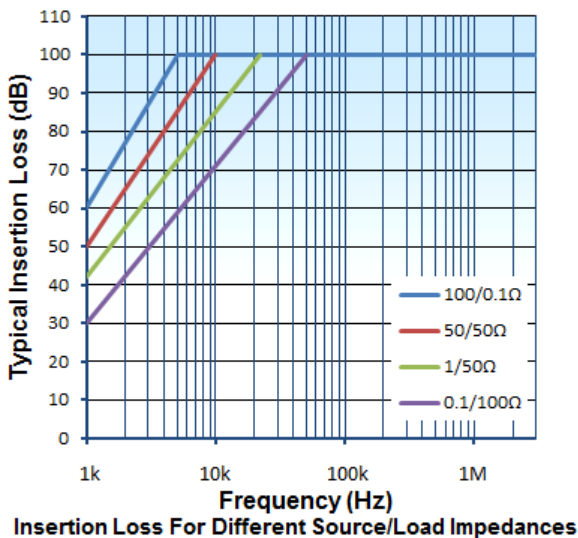

The above graph illustrates the effect of source and load impedance on insertion loss for a typical extended performance filter similar to the range shown on page 27.

Some filters in this catalogue (see page 27) have capacitive input and inductive output. The normal method of connection would be to use the capacitive input side towards the incoming mains to provide excellent high frequency transient response.

However, by connecting the filter with the inductive end facing the incoming mains, a better low frequency insertion loss may be provided in some practical situations such as where the source impedance is very low. This effect is also shown in the above graph.

More guidance on insertion loss in relation to system impedance can be given where actual impedances can be related to a particular filter.

Alternatively, custom filters can be designed to give optimum performance in a known system impedance.

Mechanical Design Features

All ranges of filters within this catalogue are of rugged construction for reliability. The tubular ranges of filters are housed in electro- tinned brass cases with epoxy resin encapsulation and end sealing and are finished in light grey military grade paint. The rectangular ranges of filters are housed in electro-tinned steel cases and are finished in light grey military grade paint.

To minimise any radiation coupling, input and output terminals on all rectangular filters are physically isolated within RFI tight terminal compartments. The lids to these compartments are supplied with both RFI and resilient gaskets to provide excellent protection against radiated interference. Lids protecting the internal filter circuitry are secured with blind rivets and then completely solder sealed to provide maximum RF integrity.

The stud terminals on all filters are bright nickel plated and are supplied with nuts and washers.

Installation

For optimum EMI performance, proper mounting of any filter is essential. It is important to ensure as low as possible earth bond impedance to the unpainted base or mounting flange of the filter. This is necessary to obtain the best insertion loss from the filter, and also to carry away high pulse currents in transient suppressed filters.

We would normally recommend that filters are mounted on a steel surface which has been electroplated with tin or zinc. This should be unpainted and must be flat and smooth. Whilst other materials and finishes may be acceptable, the user should give consideration to the shielding and earth bonding properties and

possible galvanic corrosion effects of any materials used. In most cases, "conductive paint" finishes are unacceptable as they do not permit a sufficiently good earth bond to be made.

In any EMI filter, poor earth bonding will result in reduced insertion loss and could compromise safety. On rectangular filters, the user must ensure complete screening around all conduit entries and mounting screws. "Blackened" screws and washers should not be used.

Where penetration tubes are used to pass cables through the base of the filter and the mounting surface, they must also provide a complete RF seal. Commercial conduit fittings are of variable quality and are generally unsuitable to fulfil this requirement due to badly fitting threads. MPE's dedicated fixing kits have been introduced to overcome this problem and are detailed within this catalogue (see page 37).

Rectangular filters can be supplied with different cable entry hole positions to suit alternative mounting arrangements. These are illustrated on Page 41.

Filter sizes and cable entries are designed to be a minimum for the filter current rating. The user is advised to verify that the standard filter terminal compartment and cable entry sizes are suitable for his application, especially where oversize cables may be used to minimise cable volt drop.

On rectangular filters, proper fitting of terminal compartment lids and gaskets is important, as shown in detail on Page 41. Gaskets must be fitted in the specified positions. All lid screws must be fitted and tightened to the specified torque.

Tubular filters should be installed through a metal barrier which will provide screening between input and output terminals. Terminals should be enclosed by the user for safety reasons, and for additional screening, if needed.

All conductors should pass through single cable entries in accordance with the IEE regulations to avoid eddy current heating effects

Special Applications

Use of Filters with RCCD's

All high performance power line filters incorporate comparatively large values of capacitance. This means that an RCCD can not be used ahead of the filter as the filter leakage current will cause the RCCD to trip

This applies even to low leakage filters which may still trip RCCD's due to inrush current and variable leakage current resulting from harmonics on the neutral supply.

RCCD's will normally function correctly when connected on the load side of the filter.

Other Special Applications

There are many applications where one type of filter design may be more effective than another or where special constraints may apply due to system requirements. Examples might be back-fed systems, unusual working voltage, current, or frequency, special system impedance etc. In such cases, please consult us for advice on the selection of the most suitable filter design.

Safety

All high performance filters contain capacitors which will store charge even after the power has been removed from the filter.

All of the filters listed in this catalogue are fitted with internal discharge resistor networks. These are intended to discharge the capacitors to a safe level within one minute of switching off the power.

N.B. To ensure capacitors are safely discharged, terminals must always be shorted to case and to each other (where applicable) prior to being touched.

For tubular and very high current filters, terminals must be enclosed to protect from the danger of shock. For transient suppressed versions, this is also important to protect the user in the event of a varistor rupturing following an extreme transient. For all a.c. filters, it is essential for safety that the case of the filter is **SOLIDLY AND PERMANENTLY EARTHED** in accordance with the latest IEE Regulations. On no account should these filters be connected via a plug and socket.

Great care must be taken if any bench testing is to be carried out to ensure the case is solidly earthed. Where no company earth exists, such as on portable enclosures and vehicles, then earthing should be to a buried earth spike of an equivalent standard. Good earthing is essential because in all conventional filters, in the event of the earth becoming disconnected during use, the filter case will rise in voltage to an unsafe level. Low leakage filters are safer in this respect.

For all filters, terminal polarity must be observed.

© 1994 – 2015 MPE Limited

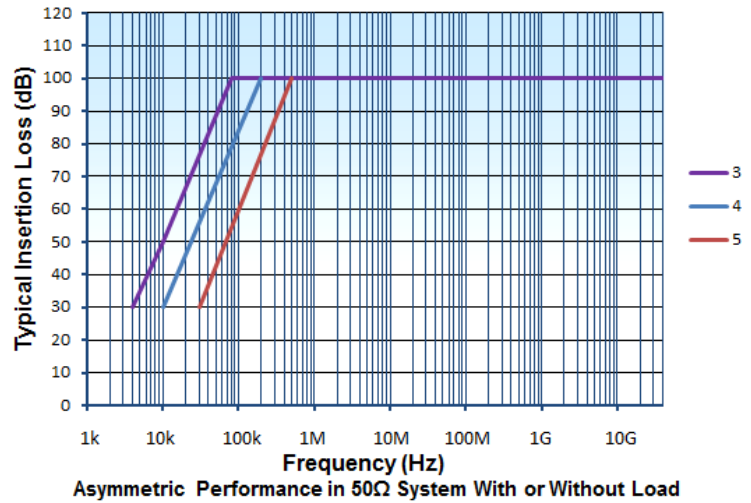

Applications

These tubular d.c. power line filters are designed for bulkhead mounting to enable high packing densities to be achieved. They are suitable for all voltages up to 250VDC. They are often used in military power supplies where their features of high performance, high current rating, and bulkhead mounting are major considerations.

The electrical circuit is symmetrical so the filters may be mounted either way round but varistors, if fitted, would always be mounted on the identified input end.

General Specification

Rated Voltage	: 250VDC (also suitable for up to 100VAC 50Hz)
Rated Current	: As tabulated below
Insertion Loss	: See graph and table Curve 3 meets 100dB from 80kHz to >10GHz Curve 4 meets 100dB from 200kHz to >10GHz Curve 5 meets 100dB from 500kHz to >10GHz
Maximum Temperature Rise on Full Load	: 25°C
Ambient Temperature Range	: -45°C to +85°C
Operating Temperature Range on Full Load	: -45°C to +50°C
Maximum Full Load Heat Dissipation	: As tabulated below
Maximum Volt Drop at Full Load Current	: As tabulated below
Discharge Time to Below 34V	: 30s maximum

Transient Suppression

All types can be supplied with a varistor transient suppressor fitted between the input terminal and earth. Varistor rating: 325VDC 110 Joules (10/1000μs)

To specify the transient suppressed version, suffix V is added to the filter part number (see ordering code).

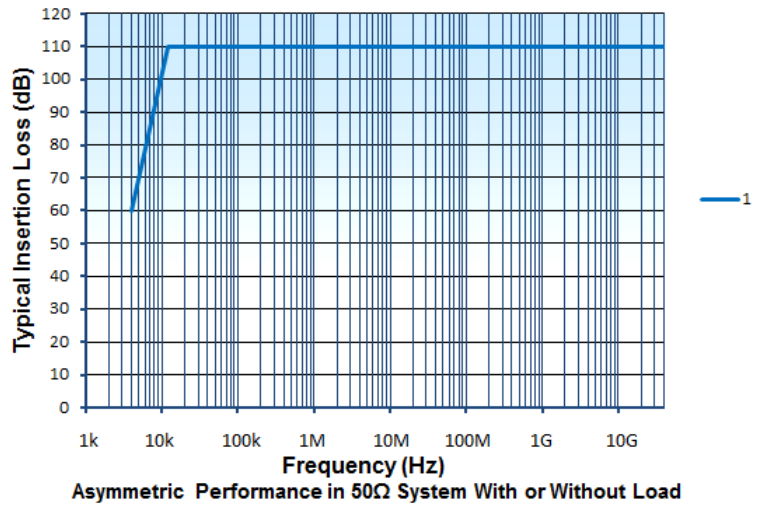

Applications

These single line d.c. power line filters in a rectangular package are designed for mounting on a bulkhead. They are suitable for all voltages up to 250VDC

These filters may also be used on low voltage a.c. power lines up to 100VAC 50Hz.

General Specification

Rated Voltage	: 250VDC (also suitable for up to 100VAC 50Hz)
Rated Current	: As tabulated below
Insertion Loss	: 100dB from 10kHz to >10GHz
Maximum Temperature Rise on Full Load	: 25°C
Ambient Temperature Range	: -45°C to +85°C
Operating Temperature Range on Full Load	: -45°C to +50°C
Maximum Full Load Heat Dissipation	: As tabulated below
Maximum Volt Drop at Full Load Current	: As tabulated below
Discharge Time to below 34V	: 60s maximum

Dimensions and Mechanical Details

See table below for major dimensions. Detailed dimensions are given on page 38. Filters are housed in electroplated steel cases.

Dimensions are given in mm.

Range Available

Current Rating I_R (A)*	MPE Part Number	Performance Curve	Volt Drop (V)	Heat Dissipation (W)	Major Dimensions (mm)			Case Size See Page 38	Approx Weight (kg)
					A	B	C		
6	DS26390	1	1	5	600	100	90	hh	12
10	DS26391	1	1	10	600	100	90	hh	12
32	DS23596	1	1	25	700	130	110	ii	20
63	DS23597	1	1	50	850	130	110	jj	25
100	DS23598	1	1	65	1000	160	130	kk	35
200	DS23599	1	1	130	1200	200	150	ll	60

*@50°C. Current derating between 50°C and 85°C

For temperature, θ $I_\theta = I_R \sqrt{(85 - \theta)/35}$

Transient Suppression

All types can be supplied with integral transient suppression fitted between the input terminal and earth.

Varistor rating: 330VDC 130 Joules (10/1000 μ s)

Other varistor ratings can also be supplied.

To specify the transient suppressed version, suffix V is added to the filter part number (see ordering code).

Typical Installation Details

Installation instructions are given on Page 41. The standard cable entry consists of an end conduit entry hole on the filter input (supply) side and a base conduit exit hole on the output (load) side.

Filters can be supplied with other cable entry positions if required. These are detailed on Page 41 and are specified by adding the appropriate suffix to the filter part number.

To facilitate installation of these filters, separate fixing kits are available to suit bulkhead panel thicknesses up to 20mm. Full details are given on page 37.

Ordering Code:

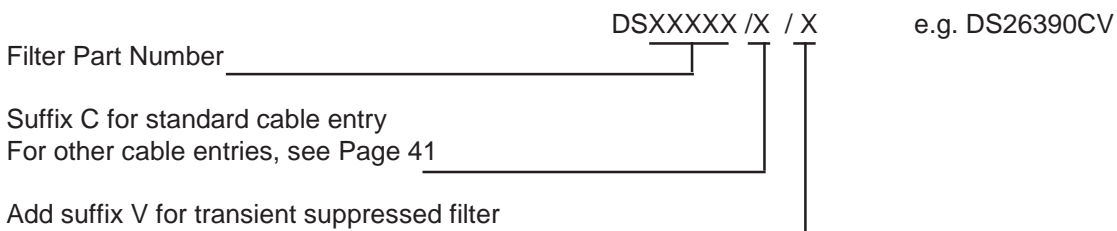



TWO LINE DC FILTERS

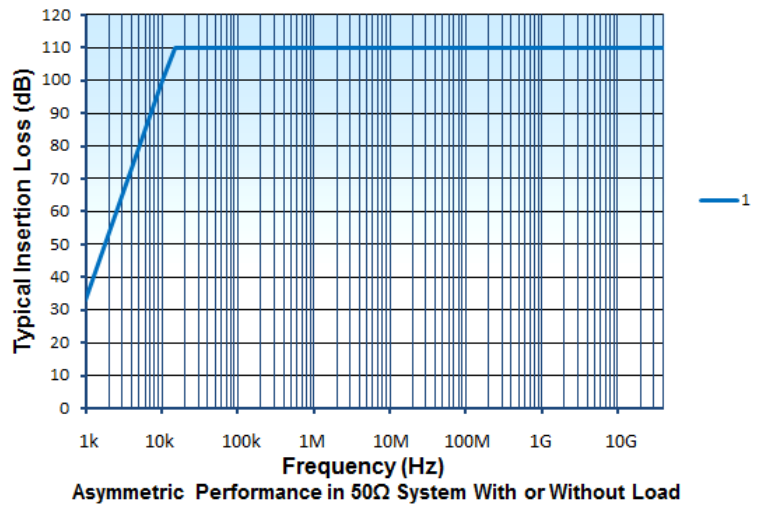

Applications

These two line d.c. power line filters feature the full benefits of using current compensating inductors as described in the technical notes on page 6. They are housed in rectangular enclosures and are designed for mounting on a bulkhead. They are suitable for all voltages up to 250VDC

To achieve the full benefits of the high performance filter design, it is important that the load current returns through the filter.

General Specification

Rated Voltage	: 250VDC (also suitable for up to 100VAC 50Hz)
Rated Current	: As tabulated below
Insertion Loss	: 100dB from 10kHz to >10GHz
Maximum Temperature Rise on Full Load	: 25°C
Ambient Temperature Range	: -45°C to +85°C
Operating Temperature Range on Full Load	: -45°C to +50°C
Maximum Full Load Heat Dissipation	: As tabulated below
Maximum Volt Drop per line at Full Load Current	: As tabulated below
Discharge Time to Below 34V	: 60s maximum

Dimensions and Mechanical Details

See table below for major dimensions. Detailed dimensions are given on page 38.

The filters are housed in electroplated steel cases.

Dimensions are given in mm.

Range Available

Current Rating I_R (A)*	MPE Part Number	Performance Curve	Volt Drop (mV)	Heat Dissipation (W)	Major Dimensions (mm)			Case Size See Page 38	Approx Weight (kg)
					A	B	C		
6	DS23870	1	500	5	310	175	90	a	8
10	DS23871	1	500	10	310	175	90	a	8
32	DS23872	1	500	20	550	205	95	e	16
63	DS23873	1	500	45	550	205	105	f	20
100	DS23874	1	500	60	640	205	120	i	25
200	DS23875	1	500	110	660	475	135	u	60

*@50°C. Current derating between 50°C and 85°C

For temperature, θ $I_\theta = I_R \sqrt{(85 - \theta)/35}$

Transient Suppression

All types can be supplied with integral transient suppression fitted between each input terminal and earth.

Varistor rating: 330VDC 130 Joules (10/1000 μ s).

Other varistor ratings can also be supplied.

To specify the transient suppressed version, suffix V is added to the filter part number (see ordering code).

Typical Installation Details

Installation instructions are given on Page 41. The standard cable entry consists of an end conduit entry hole on the filter input (supply) side and a base conduit exit hole on the output (load) side.

Filters can be supplied with other cable entry positions if required. These are detailed on Page 41 and are specified by adding the appropriate suffix to the filter part number.

To facilitate installation of these filters, separate fixing kits are available to suit bulkhead panel thicknesses up to 20mm. Full details are given on page 37.

Ordering Code:

Filter Part Number _____ DSXXXXX/X/ X e.g. DS23870CV

Suffix C for standard cable entry
For other cable entries, see Page 41 _____

Add suffix V for transient suppressed filter _____



SINGLE LINE AC FILTERS (TUBULAR)

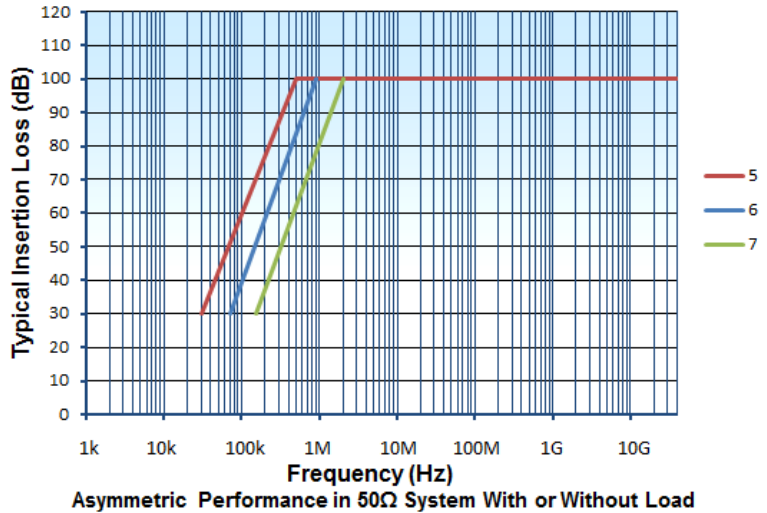

Applications

These tubular a.c. power line filters are designed for mounting through a bulkhead. Because of the end mounting gland they are suitable for high packing density. They are suitable for all voltages up to 250VAC at 50/60Hz, and may also be used on d.c. supplies up to 600VDC

General Specification

Rated Voltage	: 250VAC 50/60Hz also suitable for 277 Va.c. 50/60Hz and up to 600VDC (with alternative varistors if transient suppressed)
Rated Current	: As tabulated below
Insertion Loss	: See graph and table Curve 5 meets 100dB from 350kHz to >10GHz Curve 6 meets 100dB from 900kHz to >10GHz Curve 7 meets 100dB from 2MHz to >10GHz
Maximum Temperature Rise on Full Load	: 25°C
Ambient Temperature Range	: -45°C to +85°C
Operating Temperature Range on Full Load	: -45°C to +50°C
Maximum Full Load Heat Dissipation	: As tabulated below
Maximum Volt Drop at Full Load d.c. Current	: As tabulated below
Discharge Time to Below 34V	: 10s maximum

Transient Suppression

All types can be supplied with varistor transient suppressors fitted between the input terminal and earth. Varistor rating: 275VAC 130 Joules (10/1000µs)
Please ask about alternative varistor ratings for other voltage ratings.
To specify the transient suppressed version, suffix V is added to the filter part number (see ordering code).

Range Available

Current Rating I_R (A)*	MPE Part Number	Performance Curve	Volt Drop (mV)	Heat Dissipation (W)	Major Dimensions (mm)			Approx Weight (kg)
					A	L	W	
6	DS26088	5	325	3	165	245	M6	1.2
10	DS26089	5	200	3	180	260	M6	1.2
32	DS26090	6	200	6	195	275	M6	1.5
63	DS26091	6	200	12	215	295	M6	1.5
100	DS26092	7	120	12	195	290	M8	1.8
200	DS26093	7	120	24	195	300	M10	1.8

*@50°C. Current derating between 50°C and 85°C

For temperature, θ $I_\theta = I_R \sqrt{(85 - \theta)/35}$

Dimensions and Mechanical Details

See table above for major dimensions. The filters are housed in electroplated brass tubes and are sealed with epoxy resin. The main body of the filter is finished in light grey paint.

Dimensions are given in mm.

Mounting and terminal nuts and washers are supplied.

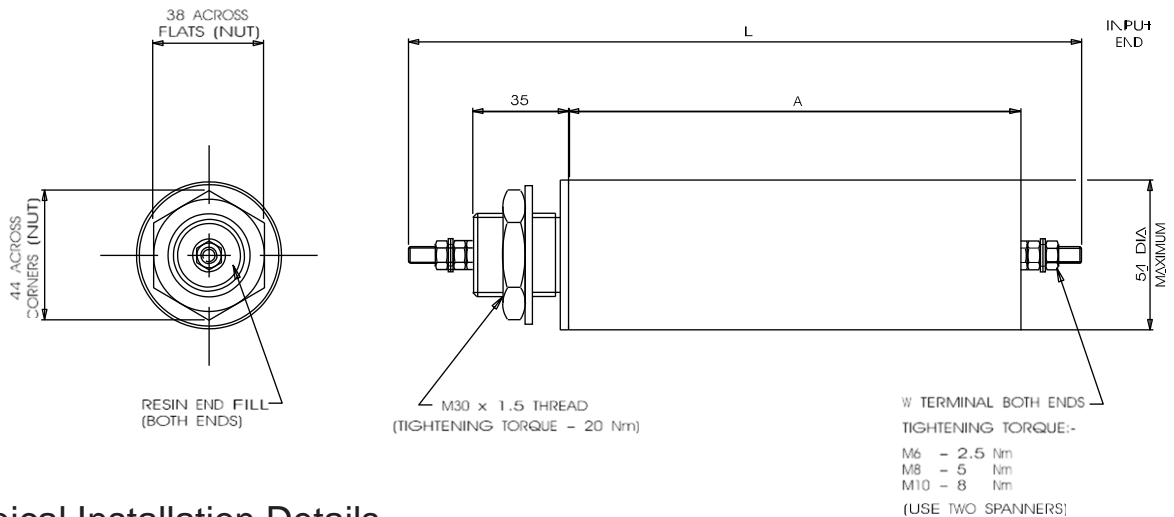

Typical Installation Details

Any paint should be removed from the bulkhead around the fixing hole to ensure a good earth bond and RF seal.

RF washers, where fitted, should be fitted between the filter and bulkhead. A plain washer should be fitted between the mounting nut and bulkhead.

Terminals should be enclosed by the user after fitting the filter to prevent any danger of electric shock, and also to provide screening of incoming and outgoing lines.

Ordering Code:

Filter Part Number _____ DSXXXXX / X

e.g. DS 26088V

Add suffix V for transient suppressed filter _____

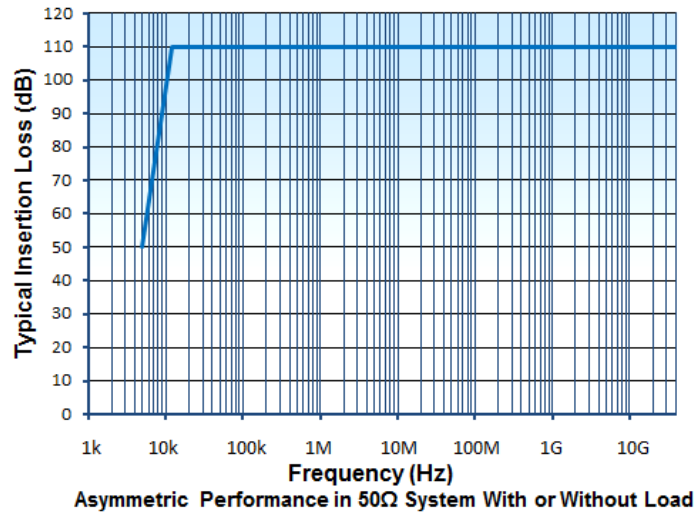

Applications

These single line a.c. power line filters in a rectangular package are designed for mounting on a bulkhead. They are suitable for all voltages up to 250VAC 50/60Hz.

They are particularly suited to high current power and control line applications where the return current has to return via a different route.

General Specification

Rated Voltage	: 250VAC 50/60Hz also suitable for 277VAC 50/60Hz and up to 600VDC (with alternative varistors if transient suppressed)
Rated Current	: As tabulated below
Insertion Loss	: 100dB from 14kHz to >10GHz
Maximum Temperature Rise on Full Load	: 25°C
Ambient Temperature Range	: -45°C to +85°C
Operating Temperature Range on Full Load	: -45°C to +50°C
Maximum Full Load Heat Dissipation	: As tabulated below
Maximum Volt Drop at Full Load d.c. Current	: As tabulated below
Discharge Time to Below 34V	: 60s maximum

Dimensions and Mechanical Details

See table below for major dimensions. Detailed dimensions are given on page 38. The filters are housed in electroplated steel cases.

Dimensions are given in mm.

Range Available

Current Rating I_R (A)*	MPE Part Number	Performance Curve	Volt Drop (V)	Heat Dissipation (W)	Major Dimensions (mm)			Case Size See Page 38	Approx Weight (kg)
					A	B	C		
6	DS26394	1	1	8	600	100	90	hh	12
10	DS26395	1	1	15	600	100	90	hh	12
32	DS26396	1	1	35	700	130	110	ii	20
63	DS26397	1	1	60	850	130	110	jj	25
100	DS26398	1	1	75	1000	160	130	kk	35
200	DS26399	1	1	150	1200	200	150	ll	60

*@50°C. Current derating between 50°C and 85°C

For temperature, θ $I_\theta = I_R \sqrt{(85 - \theta)/35}$

Transient Suppression

All types can be supplied with integral transient suppression fitted between the input terminal and earth.

Varistor rating: 275VAC 140 Joules (10/1000 μ s)

Please ask about alternative varistor ratings for other voltage ratings.

To specify the transient suppressed version, suffix V is added to the filter part number (see ordering code).

Typical Installation Details

Installation instructions are given on Page 41. The standard cable entry consists of an end conduit entry hole on the filter input (supply) side and a base conduit exit hole on the output (load) side.

Filters can be supplied with other cable entry positions if required. These are detailed on Page 41 and are specified by adding the appropriate suffix to the filter part number.

To facilitate installation of these filters, separate fixing kits are available to suit bulkhead panel thicknesses up to 20mm. Full details are given on Page 41.

Ordering Code:



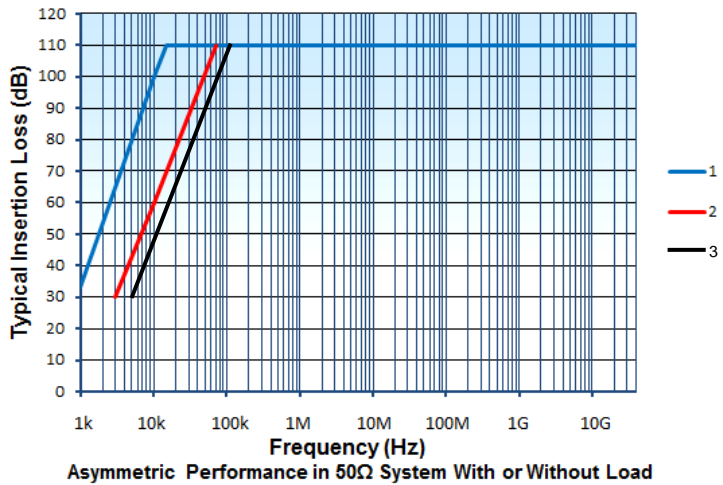

Applications

From screened rooms to industrial power equipment, uncontrolled radio interference presents a common hazard. This range of filters is designed specifically for use on single and three phase mains, and has all the advantages of using current compensating inductors.

Three phase filters are also suitable for three phase supplies without neutral. In such installations, the neutral terminal should be left unconnected.

General Specification

Rated Voltage	: Single Phase Filters	: 250VAC 50/60Hz also suitable for 277VAC 50/60Hz and 2 line d.c. supplies up to 600VDC (with alternative varistors if transient suppressed)
	: Three Phase Filters	: 250/440VAC 50/60Hz also suitable for 277/480VAC 50/60Hz (with alternative varistors if transient suppressed)
Rated Current		: As tabulated below
Insertion Loss		: See graph and table Curve 1 meets 100dB from 10kHz to >10GHz Curve 2 meets 100dB from 50kHz to >10GHz Curve 3 meets 100dB from 100kHz to >10GHz
Maximum Temperature Rise on Full Load		: 25°C
Ambient Temperature Range		: -45°C to +85°C
Operating Temperature Range on Full Load		: -45°C to +50°C
Maximum Full Load Heat Dissipation		: As tabulated below
Maximum Volt Drop per line at Full Load d.c. Current		: As tabulated below
Discharge time to below 34V		: 30s maximum

Dimensions and Mechanical Details

See table below for major dimensions. Detailed dimensions are given on page 38. The filters are housed in electroplated steel cases. Dimensions are given in mm.

Range Available

Current Rating I _R (A)*	MPE Part Number	Performance Curve	Volt Drop (mV)	Heat Dissipation (W)	Major Dimensions (mm)			Case Size See Page 38-40	Approx Weight (kg)
					A	B	C		
Single Phase (+N)									
6	DS23547	1	500	7	310	175	90	a	8
10	DS23330	1	500	11	310	175	90	a	8
16	DS23752	1	500	14	310	175	90	a	8
32	DS23332	1	500	22	550	205	95	e	16
63	DS23334	1	500	50	550	205	105	f	20
100	DS23336	2	500	60	640	205	120	i	22
200	DS23708	2	500	120	660	475	135	u	60
400	DS26050	2	500	150	1250	475	150	mm	110
Three Phase (+N)									
6	DS23619	2	500	11	310	350	90	b	16
10	DS23331	2	500	16	310	350	90	b	16
32	DS23333	1	500	45	550	410	95	g	22
63	DS23335	2	500	70	550	410	110	h	32
100	DS23337	2	500	70	660	410	135	j	45
200	DS23709	2	500	160	660	575	150	v	70
250	DS30929	3	500	180	1020	575	200	tt	100
400	DS26051	2	500	200	1250	575	150	nn	120
800	DS50026	3	100	250	900	864	285	See P40	250
1200	DS50027	3	75	350	900	1000	300	See P40	300

*@50°C. Current derating between 50°C and 85°C

For temperature, θ $I_{\theta} = I_R \sqrt{(85 - \theta)/35}$

Transient Suppression

All types can be supplied with integral transient suppression fitted between each input terminal and earth. Varistor rating: 275VAC 140 Joules (10/1000 μ s)
Please ask about alternative varistor ratings for other voltage ratings. To Specify the transient suppressed version, suffix V is added to the filter part number (see ordering code).

Typical Installation Details

Installation instructions are given on Page 41. The standard cable entry consists of an end conduit entry hole on the filter input (supply) side and a base conduit exit hole on the output (load) side.

Filters can be supplied with other cable entry positions if required. These are detailed on Page 41 and are specified by adding the appropriate suffix to the filter part number.

To facilitate installation of these filters, separate fixing kits are available to suit bulkhead panel thicknesses up to 20mm. Full details are given on page 37.

Ordering Code:

Filter part Number _____ DS XXXXX/ X / X e.g. DS23547CV

Suffix C for standard cable entry For other cable entries, see Page 41 _____

Add suffix V for transient suppressed filter _____

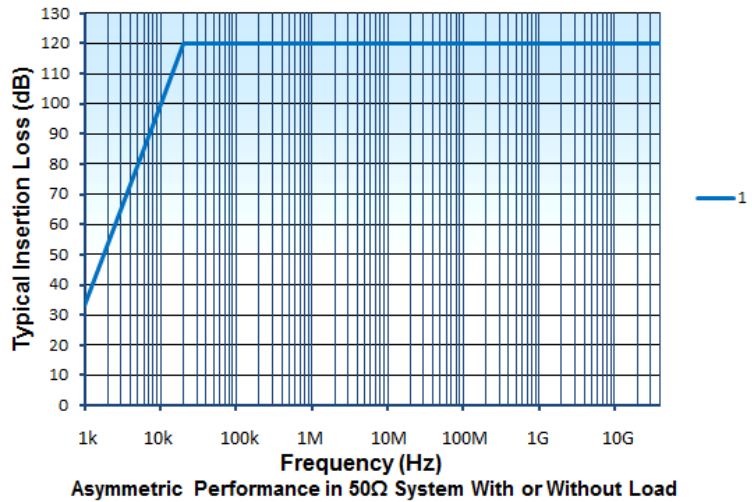

Applications

This range of filters has been designed to meet the very highest insertion loss requirement of 100dB from 10kHz to 10GHz and features an extended low frequency performance to provide considerable filter attenuation at frequencies as low as 1kHz.

Available in current ratings from 6 amps to 400 amps in both single and three phase versions, these filters are ideally suited for TEMPEST, EMP, and similar applications where the very highest performance is required.

General Specification

Rated Voltage	: Single Phase Filters	: 250VAC 50/60Hz
		also suitable for 277VAC 50/60Hz and 2 line d.c. supplies up to 600VDC (with alternative varistors if transient suppressed)
	: Three Phase Filters	: 250/440VAC 50/60Hz
		also suitable for 277/480VAC 50/60Hz (with alternative varistors if transient suppressed)
Rated Current		: As tabulated below
Insertion Loss		: 100dB from 10kHz to >10GHz
Maximum Temperature Rise on Full Load		: 25°C
Ambient Temperature Range		: -45°C to +85°C
Operating Temperature Range on Full Load		: -45°C to +50°C
Maximum Full Load Heat Dissipation		: As tabulated below
Maximum Volt Drop per line at Full Load d.c. Current		: As tabulated below
Discharge time to below 34V		: 30s maximum

Dimensions and Mechanical Details

See table below for major dimensions. Detailed dimensions are given on page 38. The filters are housed in electroplated steel cases. Dimensions are given in mm.

Range Available

Current Rating I _R (A)*	MPE Part Number	Performance Curve	Volt Drop (mV)	Heat Dissipation (W)	Major Dimensions (mm)			Case Size See Page 38	Approx Weight (kg)
					A	B	C		
Single Phase (+N)									
6	DS25940	1	500	8	310	175	90	a	8
10	DS25941	1	500	11	310	175	90	a	8
16	DS25942	1	500	15	550	205	95	e	16
32	DS25943	1	500	25	550	205	95	e	18
63	DS25944	1	500	52	640	205	120	i	22
100	DS25945	1	500	60	660	475	135	u	60
200	DS26060	1	500	120	750	500	160	pp	75
400	DS26062	1	500	160	1050	525	185	qq	110
Three Phase (+N)									
6	DS25946	1	500	12	310	350	90	b	16
10	DS25947	1	500	16	310	350	90	b	16
16	DS25948	1	500	25	550	410	95	g	22
32	DS25949	1	500	48	550	410	95	g	24
63	DS25950	1	500	70	660	410	135	j	45
100	DS25951	1	500	70	660	575	150	v	70
200	DS26061	1	500	120	750	700	170	rr	95
250	DS50024	1	500	200	1400	700	200	uu	120
400	DS26063	1	500	240	1700	700	170	ss	200

*@50°C. Current derating between 50°C and 85°C

For temperature, θ $I_{\theta} = I_R \sqrt{(85 - \theta)/35}$

Transient Suppression

All types can be supplied with integral transient suppression fitted between each input terminal and earth.

Varistor rating: 275VAC 140 Joules (10/1000 μ s)

Please ask about alternative varistor ratings for other voltage ratings

To specify the transient suppressed version, suffix V is added to the filter part number (see ordering code).

Typical Installation Details

Installation instructions are given on Page 41. The standard cable entry consists of an end conduit entry hole on the filter input (supply) side and a base conduit exit hole on the output (load) side.

Filters can be supplied with other cable entry positions if required. These are detailed on Page 41 and are specified by adding the appropriate suffix to the filter part number.

To facilitate installation of these filters, separate fixing kits are available to suit bulkhead panel thicknesses up to 20mm. Full details are given on page 37.

Ordering Code:

Filter Part Number _____ DS XXXXX /X /X e.g. DS25940CV

Suffix C for standard cable entry
For other cable entries, see Page 41

Add suffix V for transient suppressed filter

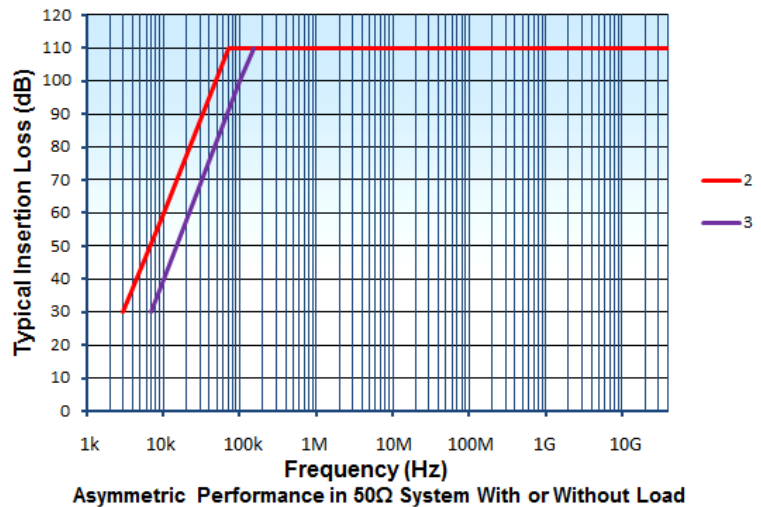

Applications

This range of single and three phase filters features a true low leakage construction offering increased levels of safety. Applications include secure communications systems, computer installations, and portable screened enclosures. These filters are designed for use on mains supplies with a dedicated neutral.

The benefits to be obtained by using MPE's proprietary low leakage filter designs together with conditions of operation are described in detail in the technical notes on page 8 of this catalogue.

General Specification

Rated Voltage	: Single Phase Filters	: 250VAC 50/60Hz also suitable for 277Vac 50/60Hz and 2 line d.c. supplies up to 600VDC (with alternative varistors if transient suppressed)
	: Three Phase Filters	: 250/440VAC 50/60Hz also suitable for 277/480VAC 50/60Hz (with alternative varistors if transient suppressed)
Rated Current		: As tabulated below
Insertion Loss		: See graph and table Curve 2 meets 100dB from 50kHz to >10GHz Curve 3 meets 100dB from 100kHz to >10GHz
Maximum Temperature Rise on Full Load		: 25°C
Ambient Temperature Range		: -45°C to +85°C
Operating Temperature Range on Full Load		: -45°C to +50°C
Maximum Full Load Heat Dissipation		: As tabulated below
Maximum Volt Drop per line at Full Load d.c. Current		: 500mV
Discharge time to below 34V		: 30s maximum
Maximum Continuous Earth Leakage Current (per Neutral-Earth Volt at 50Hz)		: As tabulated below

Dimensions and Mechanical Details

See table below for major dimensions. Detailed dimensions are given on page 38. The filters are housed in electroplated steel cases. Dimensions are given in mm.

Range Available

Current Rating I _R (A)*	MPE Part Number	Performance Curve	Leakage Current (mA)	Heat Dissipation (W)	Major Dimensions (mm)			Case Size See Page 38	Approx Weight (kg)
					A	B	C		
Single Phase (+N)									
6	DS23550	2	15	7	425	175	90	c	12
10	DS23551	2	15	11	425	175	90	c	12
16	DS26231	2	15	14	425	175	90	c	12
32	DS23552	2	25	21	550	205	95	e	16
63	DS23553	3	25	50	725	205	105	l	23
100	DS23554	3	30	60	760	205	120	n	28
200	DS25915	3	50	120	820	475	150	x	80
400	DS25917	3	100	150	1250	475	150	mm	110
Three Phase (+N)									
6	DS23620	3	30	10	425	350	90	d	18
10	DS23555	3	30	15	425	350	90	d	18
32	DS23556	3	45	42	590	410	95	w	24
63	DS23557	3	55	68	725	410	110	m	42
100	DS23558	3	95	70	780	410	135	p	55
200	DS25916	3	150	160	820	575	150	y	85
400	DS25918	3	150	170	1250	575	150	nn	120

*@50°C. Current derating between 50°C and 85°C

For temperature, θ $I_{\theta} = I_R \sqrt{(85 - \theta)/35}$

Transient Suppression

All types can be supplied with integral transient suppression fitted between each input terminal and earth.

Varistor rating: 275VAC 140 Joules (10/1000µs)

Please ask about alternative varistor ratings for other voltage ratings

To specify the transient suppressed version, suffix V is added to the filter part number (see ordering code).

Typical Installation Details

Installation instructions are given on Page 41. The standard cable entry consists of an end conduit entry hole on the filter input (supply) side and a base conduit exit hole on the output (load) side.

Filters can be supplied with other cable entry positions if required. These are detailed on Page 41 and are specified by adding the appropriate suffix to the filter part number.

To facilitate installation of these filters, separate fixing kits are available to suit bulkhead panel thicknesses up to 20mm. Full details are given on page 37.

Ordering Code:

Filter Part Number _____ DS XXXXX/ X /X

Suffix C for standard cable entry
For other cable entries, see Page 41 _____

Add suffix V for transient suppressed filter _____

e.g. DS23550CV

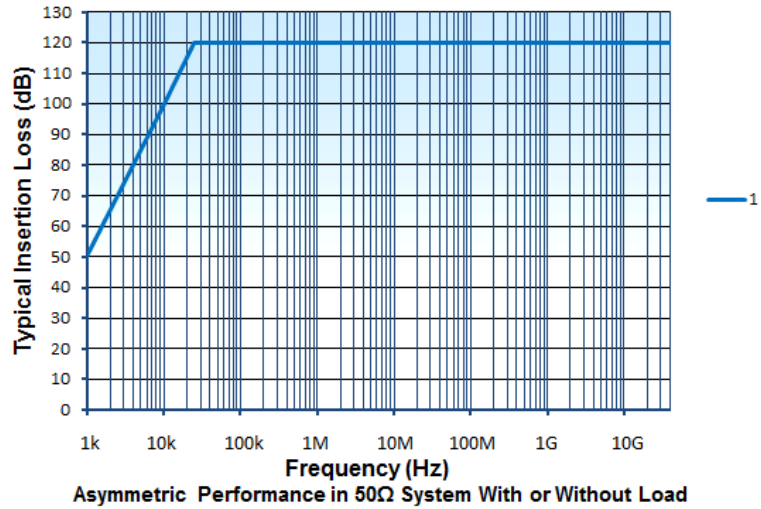

Applications

Featuring full 100dB performance down to 10kHz, these proprietary single and three phase low leakage filters were originally developed to meet stringent requirements within modern military communications systems. However, with the increasing importance of high performance at low frequency and greater emphasis on increased safety, their applicability is now widespread.

For full details of the benefits of low leakage filters and their conditions of operation, please refer to the technical notes on page 8 of this catalogue.

Capacitive input and inductive output are standard features of this range. It is worth noting that, in certain circumstances, even greater low frequency performance can be achieved by using the filter in reverse. Terminal polarity must be maintained. (Please refer to notes on page 9 for more details.)

General Specification

Rated Voltage	: Single Phase Filters	: 250VAC 50/60Hz also suitable for 277VAC 50/60Hz and 2 line d.c. supplies up to 600VDC (with alternative varistors if transient suppressed)
	: Three Phase Filters	: 250/440VAC 50/60Hz also suitable for 277/480VAC 50/60Hz.(with alternative varistors if transient suppressed)
Rated Current		: As tabulated below
Insertion Loss		: 100dB from 10kHz to >10GHz
Maximum Temperature Rise on Full Load		: 25°C
Ambient Temperature Range		: -45°C to +85°C
Operating Temperature Range on Full Load		: -45°C to +50°C
Maximum Full Load Heat Dissipation		: As tabulated below
Maximum Volt Drop per line at Full Load d.c. Current		: 1.2V
Discharge time to below 34V		: 60s maximum
Maximum Continuous Earth Leakage Current (per Neutral-Earth Volt at 50Hz)		: As tabulated below

Dimensions and Mechanical Details

See table below for major dimensions. Detailed dimensions are given on page 38. The filters are housed in electroplated steel cases. Dimensions are given in mm.

Range Available

Current Rating I _R (A)*	MPE Part Number	Performance Curve	Leakage Current (mA)	Heat Dissipation (W)	Major Dimensions (mm)			Case Size See Page 38	Approx Weight (kg)
					A	B	C		
Single Phase (+N)									
6	DS23548	1	20	15	725	175	90	k	15
10	DS23549	1	20	27	725	175	90	k	15
16	DS26232	1	20	36	725	175	90	k	15
32	DS23403	1	60	55	820	350	120	q	42
63	DS23425	1	60	115	970	350	120	r	62
100	DS23466	1	80	200	1206	350	150	s	100
200	DS23467	1	120	400	1206	573	162	t	150
400	DS26056	1	150	400	1750	650	180	z	240
Three Phase (+N)									
6	DS23852	1	50	16	725	350	95	aa	30
10	DS23853	1	50	40	725	350	95	aa	30
32	DS23854	1	120	120	820	700	120	cc	85
63	DS23855	1	200	200	970	700	150	dd	130
100	DS23856	1	240	270	1206	700	162	ee	170
200	DS23857	1	280	500	1206	930	170	ff	230
400	DS23858	1	300	500	1750	1000	180	gg	320

*@50°C. Current derating between 50°C and 85°C

$$\text{For temperature, } \theta \quad I_{\theta} = I_R \sqrt{(85 - \theta) / 35}$$

Transient Suppression

All types can be supplied with integral transient suppression fitted between each input terminal and earth.

Varistor rating: 275VAC 140 Joules (10/1000µs)

Please ask about alternative varistor ratings for other voltage ratings.

To specify the transient suppressed version, suffix V is added to the filter part number (see ordering code).

Typical Installation Details

Installation instructions are given on Page 41. The standard cable entry consists of an end conduit entry hole on the filter input (supply) side and a base conduit exit hole on the output (load) side.

Filters can be supplied with other cable entry positions if required. These are detailed on Page 41 and are specified by adding the appropriate suffix to the filter part number.

To facilitate installation of these filters, separate fixing kits are available to suit bulkhead panel thicknesses up to 20mm. Full details are given on Page 41.

Ordering Code:

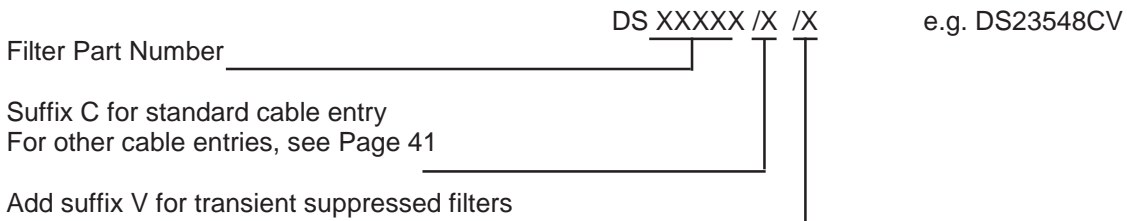

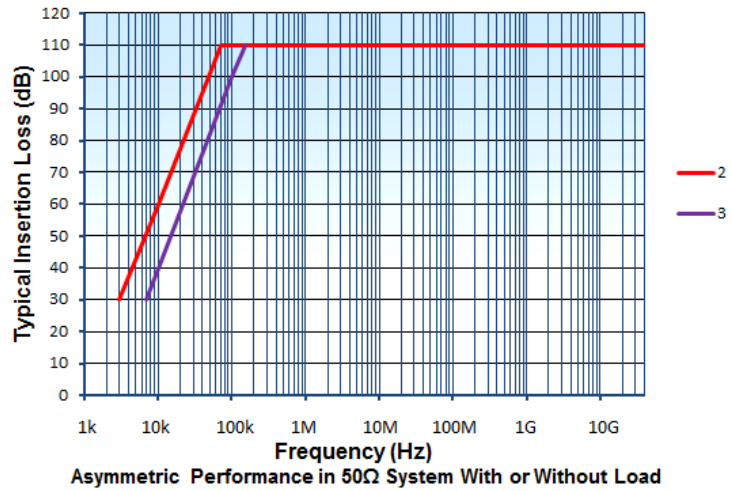

Applications

This unique range of power line filters was designed and developed by MPE to provide optimum high performance filtering on special 2 line mains supplies where neither line is tied to neutral. Examples might be: marine generator supplies, two phases taken from a three phase supply, transformer isolated supplies, and certain European grid systems.

Current ratings from 5 amps to 400 amps per phase are available. All types can be supplied fitted with varistor transient suppressors if required.

General Specification

Rated Voltage	: 250VAC 50/60Hz phase to earth : 440VAC 50/60Hz phase to phase also suitable for 480VAC 50/60Hz phase to phase and 2 line d.c. supplies up to 600VDC (with alternative varistors if transient suppressed)
Rated Current	: As tabulated below
Insertion Loss	: See graph and table Curve 2 meets 100dB from 50kHz to >10GHz Curve 3 meets 100dB from 100kHz to >10GHz
Maximum Temperature Rise on Full Load	: 25°C
Ambient Temperature Range	: -45°C to +85°C
Operating Temperature Range on Full Load	: -45°C to +50°C
Maximum Full Load Heat Dissipation	: As tabulated below
Maximum Volt Drop per line at Full Load d.c. Current	: As tabulated below
Discharge time to below 34V	: 30s maximum

Dimensions and Mechanical Details

See table below for major dimensions. Detailed dimensions are given on page 38.

The filters are housed in electroplated steel cases. Dimensions are given in mm.

Range Available

Current Rating I_R (A)*	MPE Part Number	Performance Curve	Volt Drop (mV)	Heat Dissipation (W)	Major Dimensions (mm)			Case Size See Page 38	Approx Weight (kg)
					A	B	C		
Two Phase									
6	DS26365	2	500	7	310	175	90	a	8
10	DS26366	2	500	11	310	175	90	a	8
16	DS26367	2	500	14	310	175	90	a	8
32	DS26368	2	500	22	550	205	95	e	16
60	DS26369	2	500	50	550	205	105	f	20
100	DS26370	3	500	60	640	205	120	i	22
200	DS26371	3	500	120	660	475	135	u	60
400	DS26372	3	500	150	1250	475	150	mm	110

*@50°C. Current derating between 50°C and 85°C

For temperature, θ $I_\theta = I_R \sqrt{(85 - \theta)/35}$

Transient Suppression

All types can be supplied with integral transient suppression fitted between each input terminal and earth.

Varistor rating: 275VAC 140 Joules (10/1000µs)

Please ask about alternative varistor ratings for other voltage ratings.

To specify the transient suppressed version, suffix V is added to the filter part number (see ordering code).

Typical Installation Details

Installation instructions are given on Page 41. The standard cable entry consists of an end conduit entry hole on the filter input (supply) side and a base conduit exit hole on the output (load) side.

Filters can be supplied with other cable entry positions if required. These are detailed on Page 41 and are specified by adding the appropriate suffix to the filter part number.

To facilitate installation of these filters, separate fixing kits are available to suit bulkhead panel thicknesses up to 20mm. Full details are given on page 37.

Ordering Code:

Filter Part Number _____ DS XXXXX / X / X _____ e.g. DS26365CV

Suffix C for standard cable entry
For other cable entries, see Page 41 _____

Add suffix V for transient suppressed filter _____

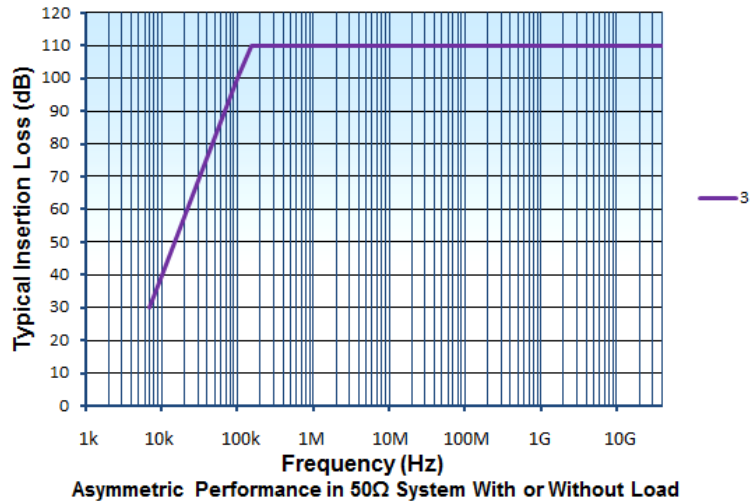

Applications

This range of filters has been specially designed for use on 400Hz systems and utilises capacitors with low loss dielectric material to minimise heat dissipation. By using coupled choke designs, it has been possible to provide a good performance with comparatively low capacitance values and hence reactive current, but it must be remembered that at 400Hz, reactive current can be significant and this current has to be supplied by the generator as well as the load current.

Many 400Hz supplies have high levels of harmonic content. This can cause additional heating within filters, so if this is known to be the case, it is better to select a filter of higher current rating than would otherwise be required. In extreme cases of harmonic content, please contact our technical department for advice.

General Specification

Rated Voltage	: Single Phase Filters	: 115VAC 400Hz
	: Three Phase Filters	: 115/200VAC 400Hz
Rated Current		: As tabulated below
Insertion Loss		: 100dB from 100kHz to >10GHz
Maximum Temperature Rise on Full Load		: 25°C
Ambient Temperature Range		: -45°C to +85°C
Operating Temperature Range on Full Load		: -45°C to +50°C
Maximum Full Load Heat Dissipation		: As tabulated below
Maximum Volt Drop per line at Full Load d.c. Current		: As tabulated below
Discharge time to below 34V		: 30s maximum

Dimensions and Mechanical Details

See table below for major dimensions. Detailed dimensions are given on page 38. The filters are housed in electroplated steel cases. Dimensions are given in mm.

Range Available

Current Rating I_R (A)*	MPE Part Number	Performance Curve	Volt Drop (mV)	Heat Dissipation (W)	Major Dimensions (mm)			Case Size See Page 38	Approx Weight (kg)
					A	B	C		
Single Phase (+N)									
6	DS25900	3	500	5	310	175	90	a	8
10	DS25901	3	500	11	310	175	90	a	8
32	DS25902	3	500	22	550	205	95	e	16
63	DS25903	3	500	50	550	205	105	f	20
100	DS25904	3	500	60	640	205	120	i	22
200	DS25905	3	500	120	660	475	135	u	60
Three Phase (+N)									
6	DS23700	3	500	7	310	350	90	b	16
10	DS23605	3	500	15	310	350	90	b	16
32	DS23606	3	500	50	550	410	95	g	22
63	DS23607	3	500	70	550	410	110	h	32
100	DS23608	3	500	70	660	410	135	j	45
200	DS25907	3	500	160	660	575	150	v	70

*@50°C. Current derating between 50°C and 85°C

For temperature, θ $I_\theta = I_R \sqrt{(85 - \theta) / 35}$

Transient Suppression

All types can be supplied with integral transient suppression fitted between each input terminal and earth.

Varistor rating: 150VAC 80 Joules (10/1000 μ s)

Other varistor ratings can also be supplied.

To specify the transient suppressed version, suffix V is added to the filter part number (see ordering code).

Typical Installation Details

Installation instructions are given on Page 41. The standard cable entry consists of an end conduit entry hole on the filter input (supply) side and a base conduit exit hole on the output (load) side.

Filters can be supplied with other cable entry positions if required. These are detailed on Page 41 and are specified by adding the appropriate suffix to the filter part number.

To facilitate installation of these filters, separate fixing kits are available to suit bulkhead panel thicknesses up to 20mm. Full details are given on page 37.

Ordering Code:

Filter Part Number _____ DS XXXXX/ X / X _____ e.g. DS25900CV

Suffix C for standard cable entry
For other cable entries, see Page 41 _____

Add suffix V for transient suppressed filter _____

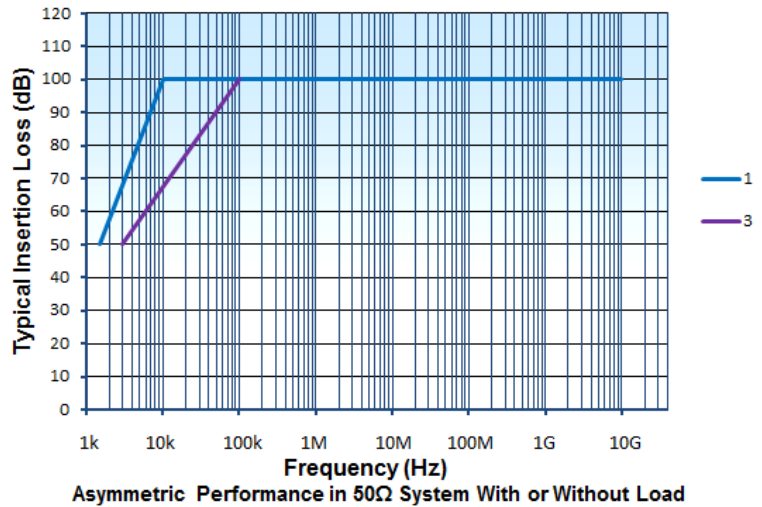

Applications

This new range of filters has been developed for use on very high current three phase and neutral mains supplies. All filters employ MPE’s proprietary low leakage filter design incorporating current compensating inductors to provide very low heat dissipation and hence running costs.

Two performance categories are offered both providing full insertion loss with or without load. These filters are ideal for use in EMP protection systems and in TEMPEST applications. Customised terminal chambers can be supplied to interface to individual installations.

All types are available with transient suppressors fitted to the input terminal busbars.

General Specification

Rated Voltage	: 250/440VAC 50/60Hz also suitable for 277/480VAC 50/60Hz (with alternative varistors if transient suppressed)
Rated Current	: As tabulated below
Insertion Loss Performance	: Standard: 100dB from 100kHz to >1GHz : Extended: 100dB from 10kHz to >1GHz (See curves 3 and 1 respectively)
Maximum Temperature Rise on Full Load	: 16°C
Ambient Temperature Range	: -45°C to +85°C
Operating Temperature Range on Full Load	: -25°C to +50°C
Maximum Full Load Heat Dissipation	: As tabulated below
Maximum Volt Drop per line at Full Load d.c.Current	: As tabulated below
Maximum d.c. Resistance per line	: As tabulated below
Discharge Time to Below 34V	: 30s maximum
Maximum Continuous Earth Leakage Current (per Neutral-Earth Volt at 50Hz)	: 250mA
Maximum Overload Current Rating	: 1.25 times rated current for 15 minutes
Maximum Short Circuit Fault Current Rating	: 20,000A for 1 second

Dimensions and Mechanical Details

See table below for major dimensions. Detailed dimensions are given on page 35.

Range Available

Current Rating I _R (A)*	MPE Part Number	DC Resistance (mΩ)	Volt Drop (mV)	Heat Dissipation (W)	Major Dimensions (mm)			Case Style See Page 35	Approx Weight (kg)
					A	B	C		
Three Phase (+N) Standard Performance									
800	DS23973	0.13	100	250	1554	864	285	A	250
800	DS23521	0.13	100	250	1554	864	285	C	250
1200	DS26310	0.07	76	350	1600	1000	300	A	300
1200	DS26311	0.07	76	350	1600	1000	300	C	300
1600	DS26320	0.04	65	400	1800	1000	350	A	350
2400	DS26330	0.03	60	500	2000	1000	400	A	450
Three Phase (+N) Extended Performance									
800	DS26307	0.2	150	375	2400	864	285	A	350
800	DS26308	0.2	150	375	2400	864	285	C	350
1200	DS26314	0.1	115	550	2500	1000	300	A	450
1200	DS26315	0.1	115	550	2500	1000	300	C	450
1600	DS26324	0.06	100	600	2900	1000	350	A	550
2400	DS26334	0.04	90	750	Please consult factory			A	650

*@50°C. Current derating between 50°C and 85°C

For temperature, θ $I_b = I_R \sqrt{(85 - \theta)/35}$

Note: Extended performance DC filters are supplied as two interlocking parts for ease of handling and installation.

Note: "C" case styles are not offered for 1600A and 2400A filters as it is more practical to use a filter with case style "A" and penetrate the shield via the terminal enclosure.

Transient Suppression

All types can be supplied with integral transient suppression fitted between each input terminal and earth.

Varistor rating: 275VAC 360 Joules (10/1000μs)

Please ask about alternative varistor ratings for other voltage ratings.

To specify the transient suppressed version, suffix V is added to the filter part number (see ordering code).

Typical Installation Details

General installation guidance notes are given on page 9. After mounting, for safety and for shielding purposes the filter terminals must be enclosed by screened covers. Custom terminal chambers and mounting frames can be supplied if required.

These filters have integral blind inserts to facilitate mounting and screening of terminal enclosures. They must not be used to support the weight of either the filter or the terminal enclosure.

Because of the very high current rating of these filters, it is important that all conductors pass through a common cable entry point in the shield to avoid eddy current heating effects.

Ordering Code:

Filter Part Number _____ DS XXXXX /X _____ e.g. DS23973V

Add suffix V for transient suppressed filter _____



Standard Performance Filters

Case Style A

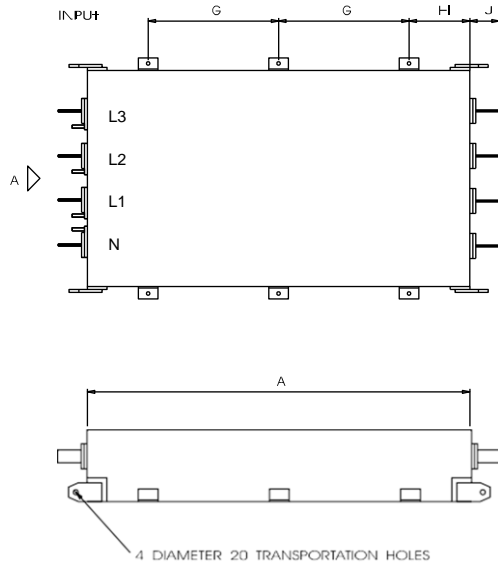

Case Style C

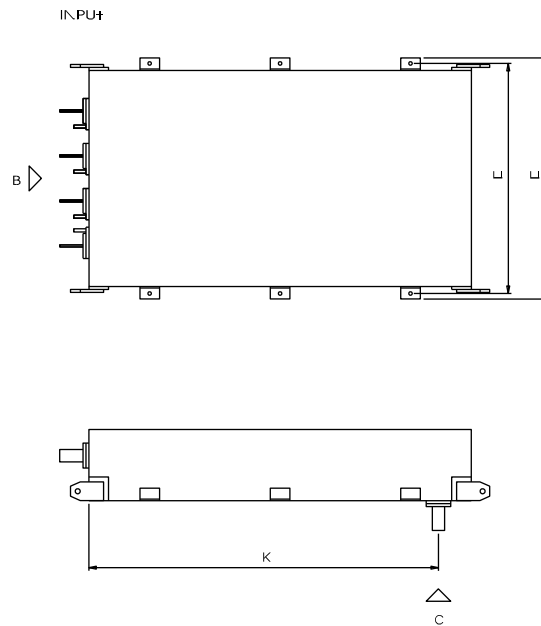

Transportation holes may be used for connection of a separate safety earth, if required.

Extended Performance Filters

Case Style A

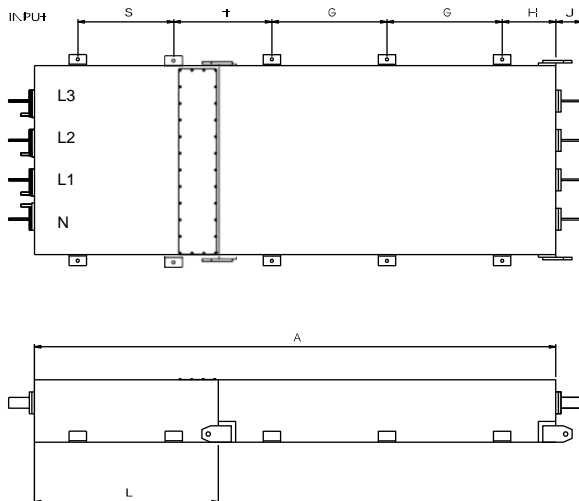

Case Style C

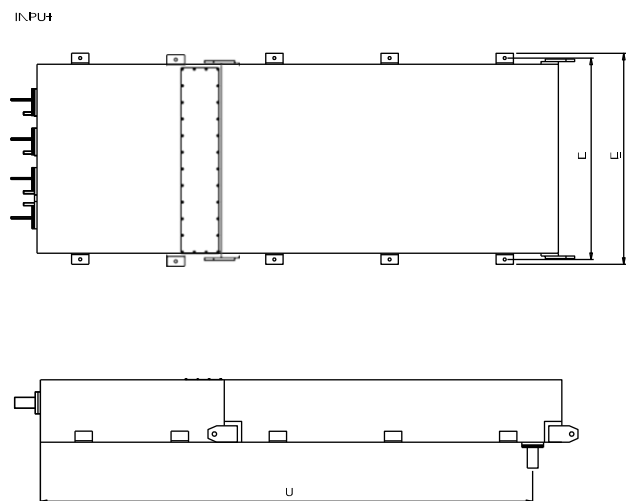

Note: Extended performance filters are supplied as two interlocking parts for ease of handling and installation. An interface gasket is supplied to join the two sections.

Terminal Details

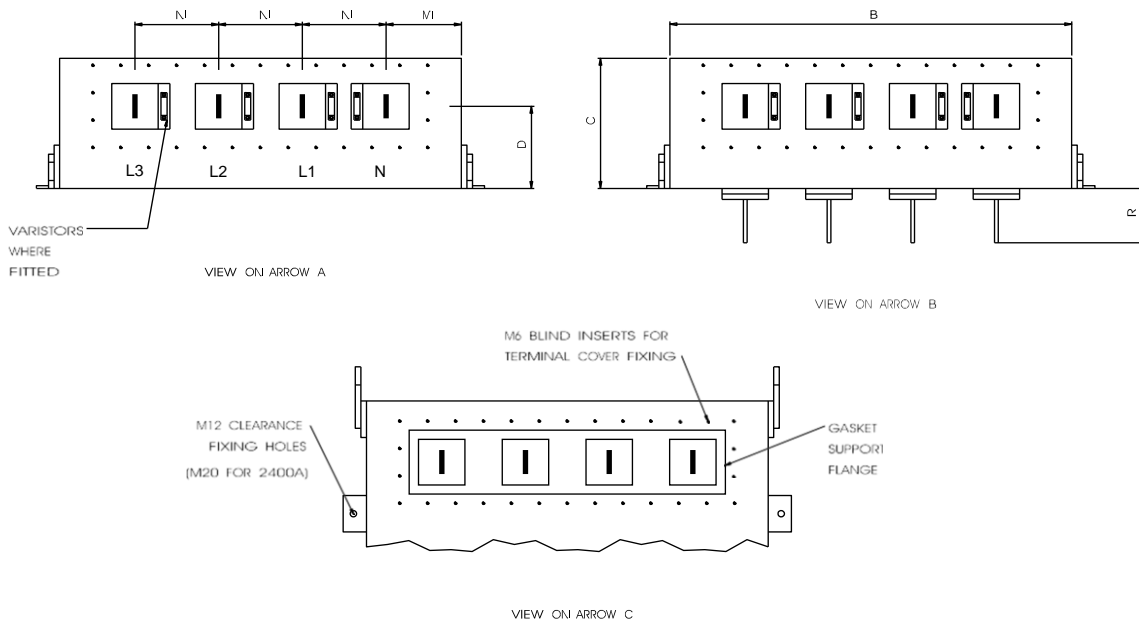

Dimensions

Filter Current Rating (A)	Dimensions of Standard Performance Filters (mm)												
	A	B	C	D	E	F	G	H	J	K	M	N	R
800	1554	864	285	180	964	920	530	247	125	1420	162	180	125
1200	1600	1000	300	185	1100	1056	600	200	155	1450	125	250	155
1600	1800	1000	350	212	1100	1056	700	200	200	-	125	250	-
2400	2000	1000	400	230	1112	1056	800	200	200	-	125	250	-

Filter Current Rating (A)	Dimensions of Extended Performance Filters (mm) (where different from above)				
	A	L	S	T	U
800	2400	846	442	450	2265
1200	2500	900	447	428	2350
1600	2900	1100	550	478	-
2400	Please consult factory				

Filter Current Rating (A)	Busbar Size (mm)
800	50 x 8
1200	80 x 10
1600	125 x 10
2400	127 x 16



These high quality fixing kits have been designed to provide an RFI tight bulkhead penetration for cables to facilitate fixing of rectangular filters to bulkheads or walls of shielded enclosures. They make it easier to achieve a full RFI seal between filter case and bulkhead up to the highest frequencies, which is not usually achievable with standard electrical conduit fittings due to badly fitting threads.

Each bulkhead fixing kit comprises a penetration tube complete with nuts, heavy duty washers, gaskets, and end bushes for cable protection. The main components are made from electro-tinned steel. The fixing kit is ordered by specifying the MPE part number in the table below.

Fixing screw sets are also available separately. These are made from electro-tinned steel and comprise a set of four screws each with washers, nuts, and spring washers. They are selected by choosing the thread size appropriate to the filter fixing hole diameter.

Bulkhead Fixing Kits



Cable Entry Hole Diameter (mm)	MPE Part Number Bulkhead Thickness up to 20mm
16	807146
20	807147
25	807148
32	807149
40	807150
50	807151
63	807152
75	807153

Fixing Screw Sets



Fixing Hole Diameter (mm)	Screw Thread Size (mm)	MPE Part Number Bulkhead Thickness up to 20mm
4.5	M4	806950
5.5	M5	806951
7	M6	806952
9	M8	806953
11	M10	806954
13	M12	806955
17	M16	806956
21	M20	806957



OUTLINE DIMENSIONS

Dimensions are tabulated below for rectangular style filters. They apply to the standard cable entry style. (i.e. suffix C on filter part number - see Page 41)

All dimensions are given in mm

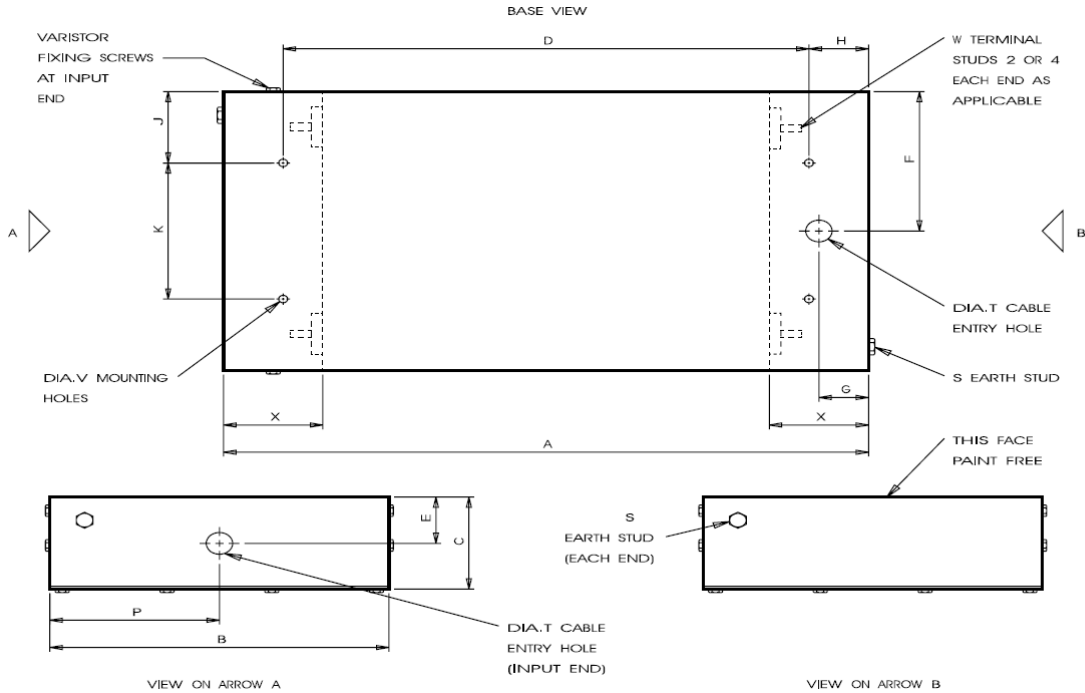

Normal configuration is for the neutral terminal to be adjacent to the earth terminal at the supply end of the filter.

CASE SIZE	Table of Dimensions (mm)															
	A	B	C	D	E	F	G	H	J	K	P	S	T	V	W	X
a	310	175	90	212	45	88	35	49	24	127	88	M6	20	9	M5	65
b	310	350	90	212	45	175	35	49	67	216	175	M6	25	9	M5	65
c	425	175	90	327	45	88	45	49	24	127	88	M6	20	9	M5	85
d	425	350	90	327	45	175	45	49	67	216	175	M6	25	9	M5	85
e	550	205	95	487	48	103	45	31	61	83	103	M10	32	9	M8	85
f	550	205	105	487	48	103	45	31	61	83	103	M10	32	9	M8	85
g	550	410	95	487	48	205	45	31	62	286	205	M10	32	9	M8	85
h	550	410	110	487	48	205	45	31	62	286	205	M10	32	9	M8	110
i	640	205	120	537	48	103	65	52	61	83	103	M10	32	9	M8	110
j	660	410	135	537	68	205	75	62	62	286	205	M10	32	9	M8	120
k	725	175	90	627	45	88	45	49	24	127	88	M6	20	9	M5	85
l	725	205	105	621	48	103	55	52	61	83	103	M10	32	9	M8	110

CASE SIZE	Table of Dimensions (mm)															
	A	B	C	D	E	F	G	H	J	K	P	S	T	V	W	X
m	725	410	110	663	48	205	55	31	62	286	205	M10	32	9	M8	110
n	760	205	120	656	48	103	55	52	61	83	103	M10	32	9	M8	110
p	780	410	135	656	68	205	60	62	62	286	205	M10	32	9	M8	120
q	820	350	120	710	60	175	55	55	110	130	175	M10	32	13	M8	110
r	970	350	120	860	60	175	55	55	110	130	175	M10	32	13	M8	110
s	1206	350	150	1130	75	175	60	38	110	130	175	M10	32	13	M8	120
t	1206	573	162	1130	81	286	75	38	110	353	286	M12	51	13	M12	135
u	660	475	135	537	68	238	60	62	110	255	238	M12	51	13	M12	120
v	660	575	150	537	75	288	60	62	110	355	288	M12	51	13	M12	120
w	590	410	95	527	48	205	45	31	62	286	205	M10	32	9	M8	85
x	820	475	150	680	75	238	70	70	110	255	238	M12	51	13	M12	140
y	820	575	150	680	75	288	70	70	110	355	288	M12	51	13	M12	140
Z	1750	650	180	1260	90	325	75	245	150	350	325	M20	63	17	M20	300
aa	725	350	95	635	47	175	45	45	85	180	175	M6	20	9	M5	85
bb	725	350	95	635	47	175	45	45	85	180	175	M6	20	9	M5	85
cc	820	700	120	710	60	350	55	55	175	350	350	M10	32	13	M8	110
dd	970	700	150	860	75	350	55	55	175	350	350	M10	32	13	M8	110
ee	1206	700	162	1086	81	350	60	60	175	350	350	M10	32	17	M8	120
ff	1206	930	172	1070	85	465	68	68	230	470	465	M12	51	17	M12	135
gg	1750	1000	180	1260	90	500	75	245	250	500	500	M20	75	17	M20	300
hh	600	100	90	540	45	50	30	30	20	60	50	M6	20	9	M5	65
ii	700	130	110	640	55	65	30	30	30	70	65	M10	25	13	M8	65
jj	850	130	110	770	55	65	40	40	30	70	65	M10	25	13	M8	85
kk	1000	160	130	870	65	80	65	65	30	100	80	M10	32	13	M8	130
ll	1200	200	150	1070	75	100	65	65	40	120	100	M12	51	17	M12	130
mm	1250	475	150	760	75	238	75	245	110	255	238	M20	63	17	M20	300
nn	1250	575	150	760	75	288	75	245	110	355	288	M20	75	17	M20	300
pp	750	500	160	620	80	250	60	65	130	240	250	M12	40	13	M12	120
qq	1050	525	185	660	93	263	60	195	130	265	263	M20	51	13	M20	250
rr	750	700	170	620	85	350	60	65	150	400	350	M12	51	13	M12	120
ss	1700	700	170	1210	85	350	75	245	150	400	350	M20	75	17	M20	300
tt	1020	575	200	870	75	287.5	75	75	110	355	287.5	M16	63	13	M16	300
uu	1400	700	200	1250	75	240	75	75	110	240	350	M16	63	13	M16	300



Standard performance powerline filter DS50026 250/440VAC TP&N 4x800A dimensions

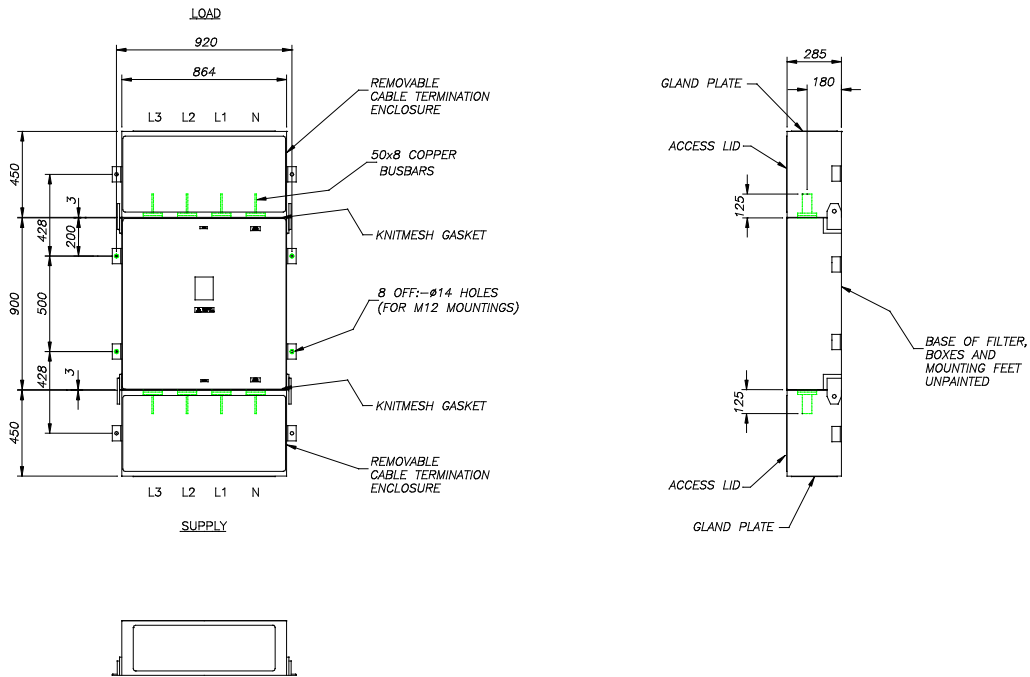

Standard performance powerline filter DS50027 250/440VAC TP&N 4x1200A dimensions

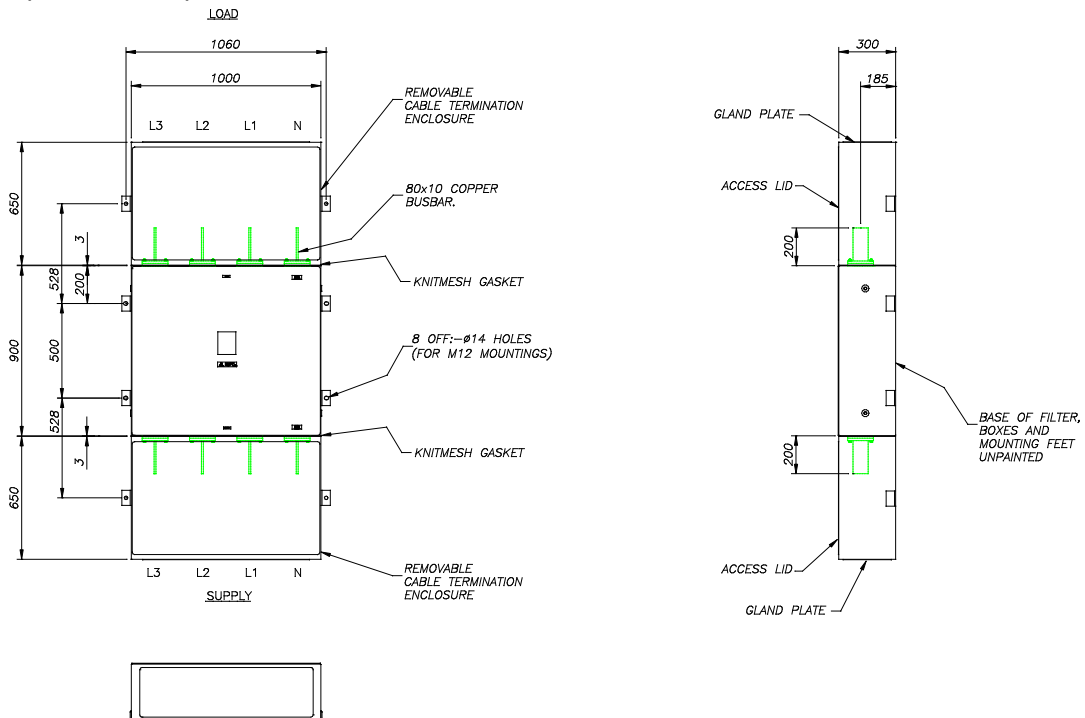



Typical installation details are shown below. See page 9 for further technical information relating to installation.

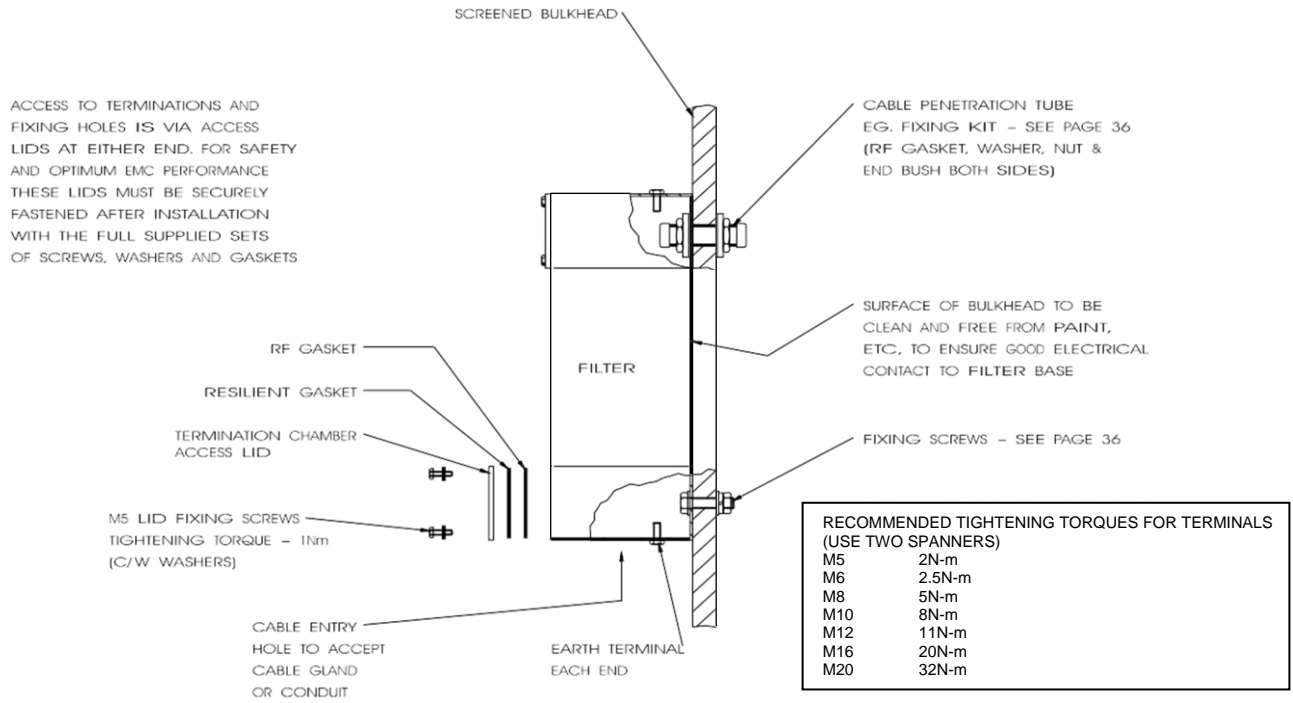

Cable Entry Options

The following standard cable entry hole positions are available on all rectangular filters with terminal compartments. The required cable entry is simply specified by adding the appropriate suffix to the filter part number as shown below. Other cable entries can be provided to special order.

Suffix "C" denotes the standard version and this type will be supplied in the event of no cable entry suffix being specified.

Note: Transient suppressors, where fitted, are always on the input end of the filter.

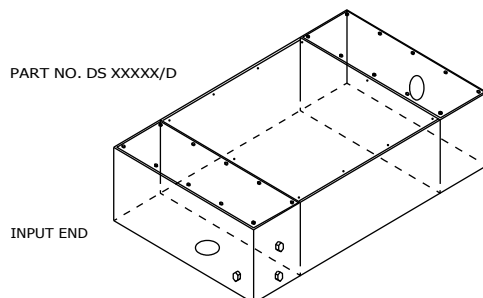
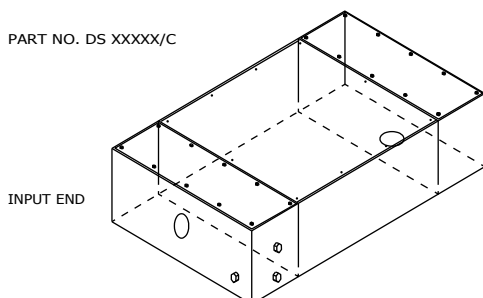
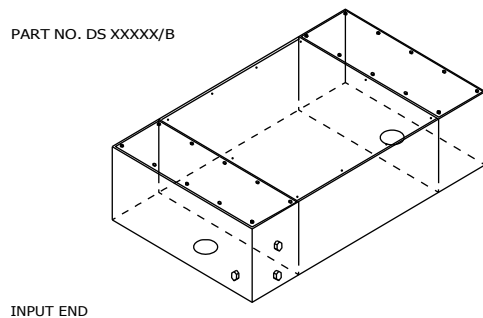
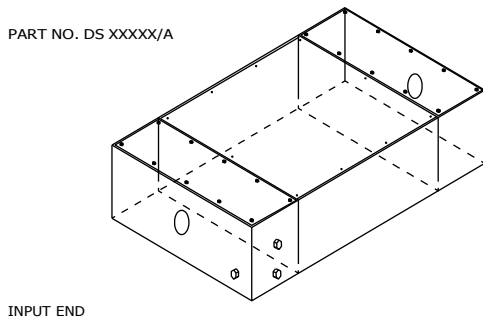



MPE
Quality, Reliability, Performance

CUSTOM DESIGNS

The products detailed within this catalogue comprise one of the most comprehensive ranges of power line filters currently available, and should fulfil most system requirements.

Whilst standard catalogue filters should always be specified as a preferred option, MPE recognise that there will inevitably be instances where non-standard filters are required. We are always prepared to offer specialist advice and guidance on custom solutions to specific EMC problems.

Some of the areas where we have previously helped our customers include:-

Modified filter circuitry to suit unusual terminating impedances.

Special filter circuitry to meet non-standard performance requirements.

Filters for supplies with high harmonic content.

Special voltage and current requirements.

High shock and vibration capability.

Reduced magnetic signature filters.

Customised mounting hardware.

Extended terminal compartments to suit oversize cables.

Special cable entry sizes and positions.

Interfaces to trunking and distribution boards.

To discuss your custom requirements with one of our filter engineers, please contact us

MPE Sales Line:	+44 (0) 151 632 9100
MPE Fax:	+44 (0) 151 632 9122
MPE Sales Email	sales@mpe.co.uk
MPE Web Site:	www.mpe.co.uk