



**MPE**  
Quality, Reliability, Performance

**1200A THREE PHASE HEMP FILTER DS33753**

**1200A THREE PHASE + NEUTRAL  
EXTENDED PERFORMANCE  
HEMP POWER LINE FILTER  
PART NUMBER DS33753**



**MEETS ELECTRICAL POINT-OF-ENTRY  
REQUIREMENTS OF MIL-STD-188-125-1 & -2  
AND DEF STAN 59-188 PART 1 AND PART 2  
FOR SHORT AND INTERMEDIATE PULSES**



**MPE Limited**  
Hammond Road  
Knowsley Industrial Park  
Liverpool L33 7UL  
UK



## Insertion Loss

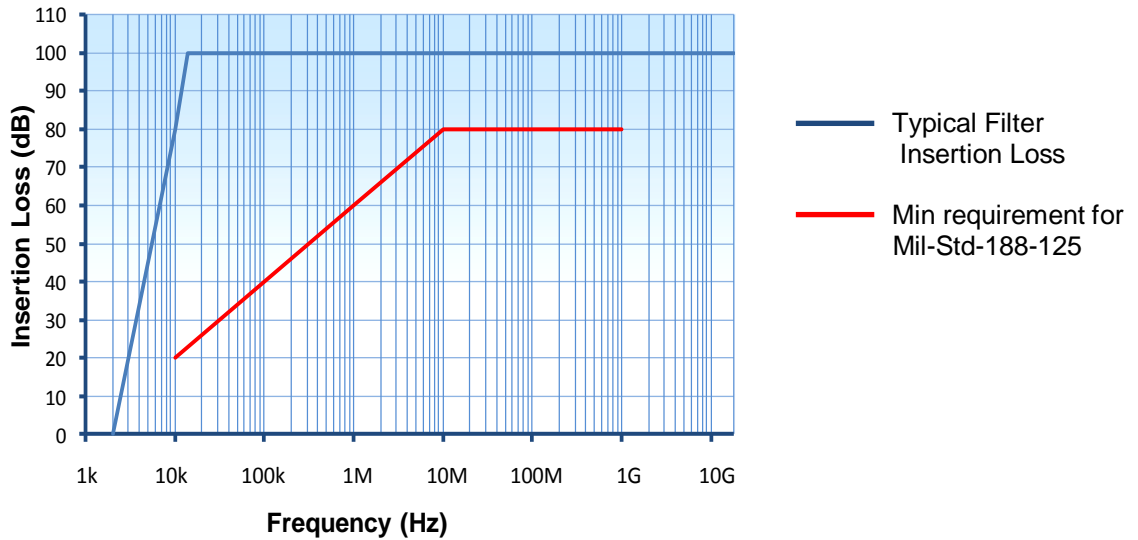

## Description

1200A Three Phase Extended Performance Power Line HEMP filter meeting the pci requirements of Mil-Std-188-125-1 and -2 and Def Stan 59-188 parts 1 and 2 for E1 and E2 pulses. Meets an insertion loss performance of 100dB from 14kHz to 18GHz for applications where high insertion loss is required in addition to HEMP performance. The filter has no internal parallel filter circuits and features inductive input to offer both good continuous wave EMC performance and superior transient handling performance even on supplies with low source impedance. The filter is fitted with high-energy transient suppressors.

Customised end enclosures are normally fitted to provide screening of input and output terminals, and to interface with the customer's connection requirements.

## Features

- 250/440Vac and 277/480Vac versions
- Utilises MPE self-healing feedthrough capacitors
- Smaller & lighter than traditional solutions
- Lower heat dissipation than traditional solutions
- High energy transient suppressors for reliability (will survive >200 pulses without degradation)
- No internal paralleling of filter components
- Exceeds IEC 950 and UL1283 requirements for voltage proof for safety and reliability
- Reliable capacitor technology proven over 25 years
- Low residual pulse current – high safety margin

## Ratings and Characteristics

Rated Voltage	250/440Vac 50/60 Hz or 277/480Vac 50/60Hz
Test Voltage (Prior to fitting transient suppressors)	2250Vdc each line to case
Rated Current per Line @40°C *	1200A
Insulation Resistance (Prior to fitting discharge resistors)	>100MΩ
Discharge Resistors	Fitted internally from each line to case
Discharge Time to below 34V	<60s
Maximum Temperature Rise on Full Load	25°C
Full Load Operating Temperature Range	-40°C to +40°C
No Load Operating / Storage Temperature Range	-40°C to +85°C
Leakage Current at 250Vac 50Hz	<17A
Maximum DC Volt drop per line at 1200Adc	116mV
MTBF ( iaw Mil HDBK 217D excl varistors)	>0.5 million hours
Peak Surge Current of Transient Suppressors	70kA (8/20μs)
Varistor Voltage Rating: 250V versions	275Vac
277V versions	480Vac

\* Current derating between 40°C and 85°C  $I_{\theta} = I_R \sqrt{(85 - \theta)/45}$



## Insertion Loss Performance

Insertion loss In 50Ω system with / without load						
Frequency	10kHz	14kHz	100kHz	1MHz	10MHz-100MHz	1GHz – 18GHz
Minimum HEMP insertion loss requirement (Mil-Std- 188-125)	20dB	As graph	40dB	60dB	80dB	N/A
Typical filter insertion loss	80dB	100dB	100dB	100dB	100dB	100dB

## Transient Suppression Performance

MIL STD 188-125-1 acceptance test, short pulse current injection, wave shape 20/500ns						
Input pulse amplitude	250A	500A	1000A	1800A	2500A	
MIL-STD-188-125 residual requirement	<10A	<10A	<10A	<10A	<10A	<10A
Typical filter residual let-through (250/440V version)	<7.1A	<7.1A	<7.1A	<7.1A	<7.1A	<7.1A

MIL STD 188-125-1 acceptance test, intermediate pulse current injection, wave shape 1.5/3000µs	
Input pulse amplitude	250A
MIL-STD-188-125 requirement	No filter damage or performance degradation
Typical filter response	No filter damage or performance degradation

## Typical Installation Details

Because every installation of such high current filters is different, customised shielded termination enclosures are usually required to interface with the cables or busbars used for power connections.

Both ends of the filter are provided with blind inserts to make a good quality shielded interface to external terminal chambers. Wire mesh EMI gaskets are needed between the filters and the terminal chambers at the protected end of the filters. One gasket is provided with each filter, and additional gaskets can be ordered, if required, for use at the other end of the filter.

MPE can provide customised terminal compartments to interface with these filters, or alternatively, the user can provide his own, but must ensure that clean unpainted and flat mating surfaces are used to interface to the filter via the wire mesh gasket. The interface fixing bolts (M6) should be tightened to a maximum torque of 2.5N-m. (22lbf-in).

Note that to avoid eddy current heating in the shield and/or termination boxes, all four power cables should be passed through a single cable entry hole and shield penetration hole, rather than through separate holes for each phase.

## Safety

Relevant safety standards have been adhered to in the design and manufacture of these filters. However, all capacitors will store charge after power has been removed and must be treated with respect as a shock can be lethal if the voltage and charge are high enough. Even though discharge resistors are fitted to these filters, terminals should always be shorted to earth prior to touching to ensure the capacitors are fully discharged.

The user should ensure he is familiar with restrictions on capacitance value, earth leakage current, test voltage, and safety labelling requirements, which may be applicable to his particular installation.

These filters must be solidly and permanently earthed, both for safe operation and to achieve optimum EMC and pulse performance.

## Ordering Information

Three Phase + Neutral Extended Performance HEMP Filter for 250/440VAC 50/60Hz

Order part no DS33753

Three Phase + Neutral Extended Performance HEMP Filter for 277/480VAC 50/60Hz

Order part no DS33753/480

Additional wire mesh interface gasket

Order part no 64/808010



**Dimensions and Mechanical Details**

Dimensions in mm

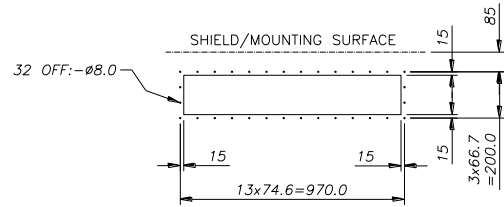
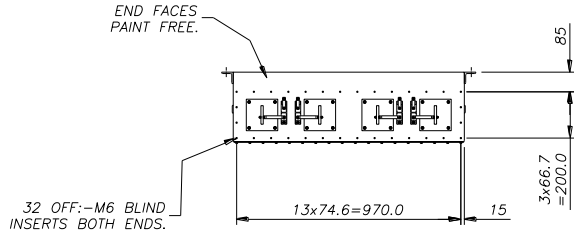

RECOMMENDED CUTOUT DETAIL FOR TERMINATION ENCLOSURES

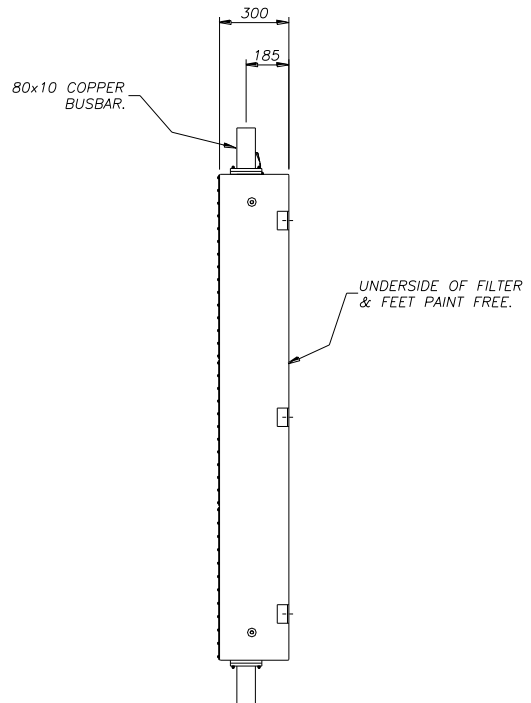
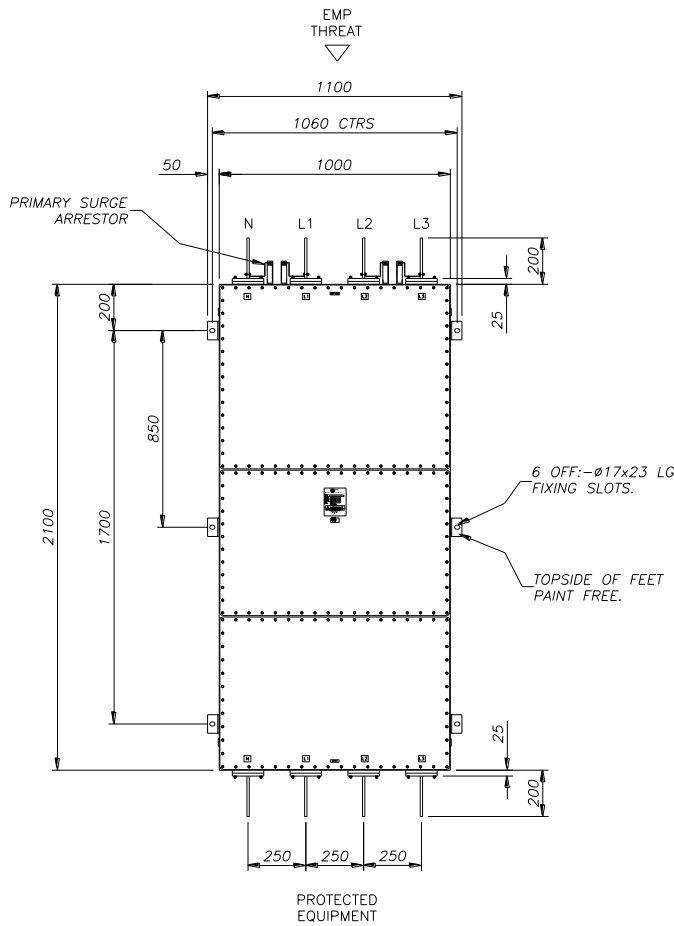

Material: Stainless steel  
 Finish: Paint (base & ends paint free)  
 Approx. Weight: 450kg